

Compact Inverter YD180 Series User Manual

200V class 0.4 – 2.2kW
400V class 0.75 – 2.2kW

- Please read this User Manual carefully
- Please give this manual to the end user and keep
- The technical specifications of this product and are subject to change without notice



Solemnly declared

Thank you for using the inverter, before use, be sure to read this instruction manual carefully, please be familiar with the safety precautions of this product before use.

Safety Precautions:

1. Before wiring, please confirm whether the input power supply is in a power-off state.
2. For wiring operations, professional electrical engineers should be invited to carry out the work.
3. Grounding terminal, please be sure to ground.
4. After the emergency stop circuit wiring is completed, please be sure to check whether the action is effective.
5. The output line of the inverter should not be connected with the shell, and the output line should not be short-circuited.
6. Please confirm whether the voltage of the AC main circuit power supply is consistent with the rated voltage of the inverter.
7. Do not carry out withstand voltage test on the inverter.
8. Please connect the braking resistor according to the wiring diagram.
9. Do not connect the power cord to the output U, V, or W terminals.
10. Do not connect the contactor to the output circuit.
11. Be sure to install a protective cover before powering on. When removing the cover, be sure to disconnect it from the power supply.
12. Select the inverter with the reset and retry function, and do not get close to the mechanical equipment. This is because it will suddenly restart when the alarm stops.
13. After confirming that the running signal is cut off, the alarm can be reset. Alarm reset is possible in the operating signal state, and the inverter is possible
It will start suddenly.
14. Do not touch the terminal of the inverter, there is high voltage on the terminal, which is very dangerous.
15. During power-on, please do not change the wiring and terminal disassembly.
16. Cut off the power supply of the main circuit before inspection and maintenance.
17. Do not modify the inverter without authorization.

Model Name

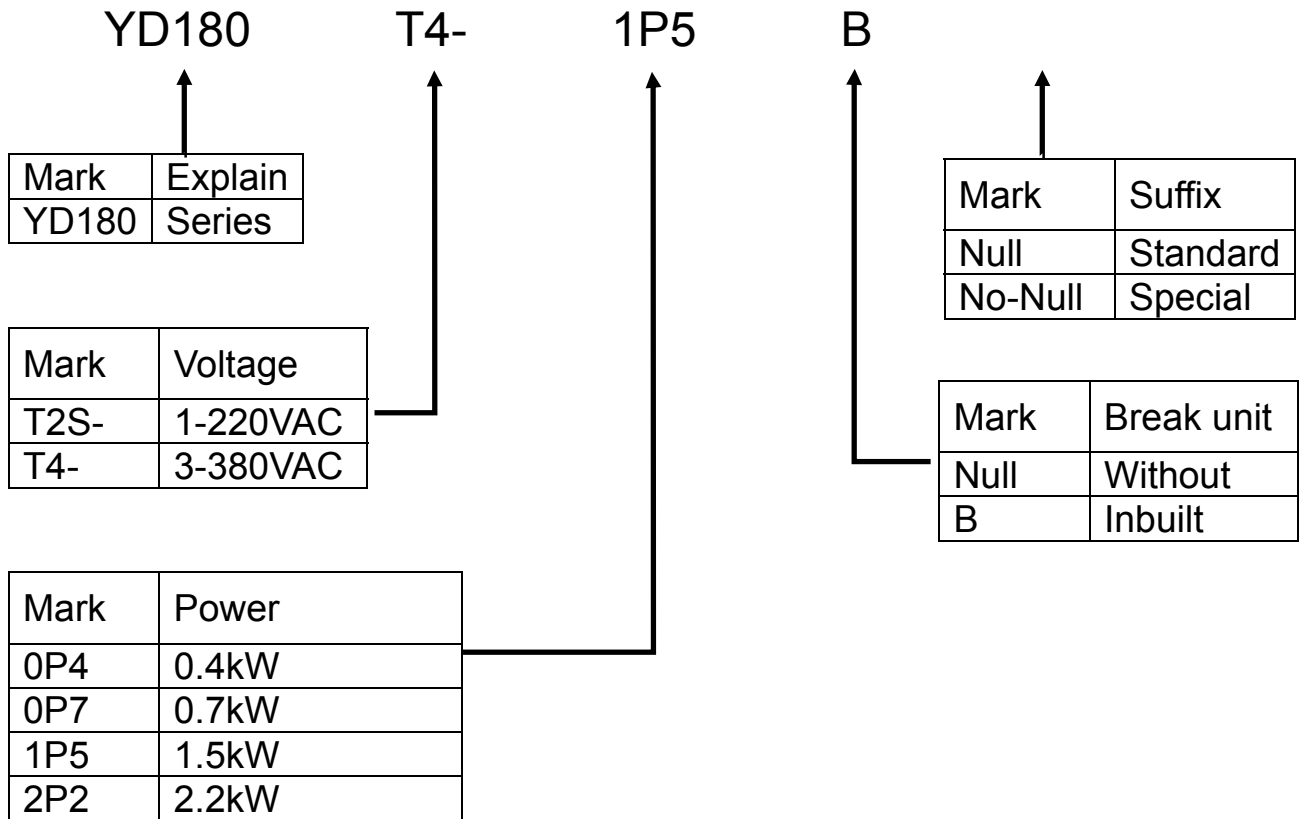

1. Technical Specification

Inverter Rating data					
Type	Power	Input Voltage (AC)	Output Current (A)	Dimension HxWxD (mm)	Install-Dimen HxW-screw (mm)
YD180T2S-0P4B	0.4kW	1-PH 200-240V	2.1	172.3x79x128.5	158x60-M5
YD180T2S-0P7B	0.75kW		3.8		
YD180T2S-1P5B	1.5kW		7.0		
YD180T2S-2P2B	2.2kW		9.0	190.5x86x145	170x68-M4
YD180T4-0P7B	0.75kW	3-PH 340-440V	2.1	172.3x79x128.5	158x60-M5
YD180T4-1P5B	1.5kW		3.8		
YD180T4-2P2B	2.2kW		5.1	190.5x86x145	170x68-M4

Brake Resistor Selection

Type	Power	Input Voltage (AC)	Brake resistance power 10% (W)	Brake resistance value (Ω)
YD180T2S-0P4B	0.4kW	1-PH 200-240V	100	250
YD180T2S-0P7B	0.75kW		100	200
YD180T2S-1P5B	1.5kW		300	100
YD180T2S-2P2B	2.2kW		300	100
YD180T4-0P7B	0.75kW	3-PH 340-440V	100	750
YD180T4-1P5B	1.5kW		300	400
YD180T4-2P2B	2.2kW		300	250

Panel holder size

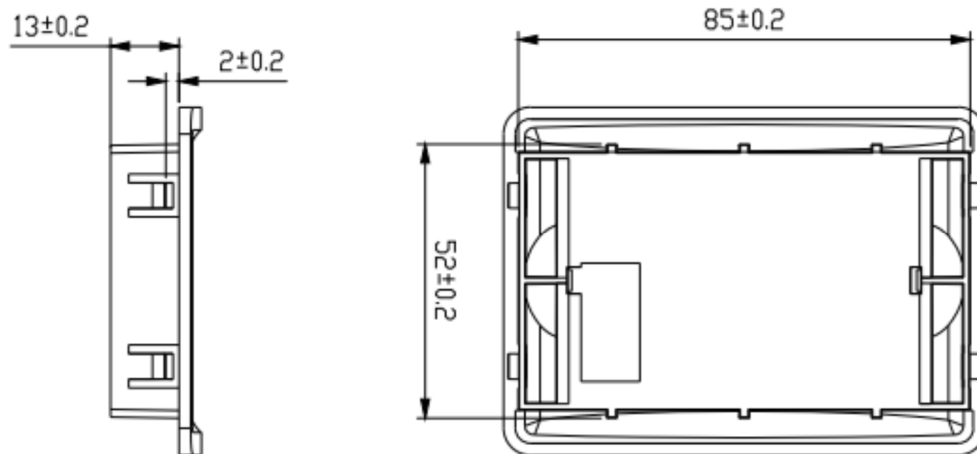

Installation and wiring

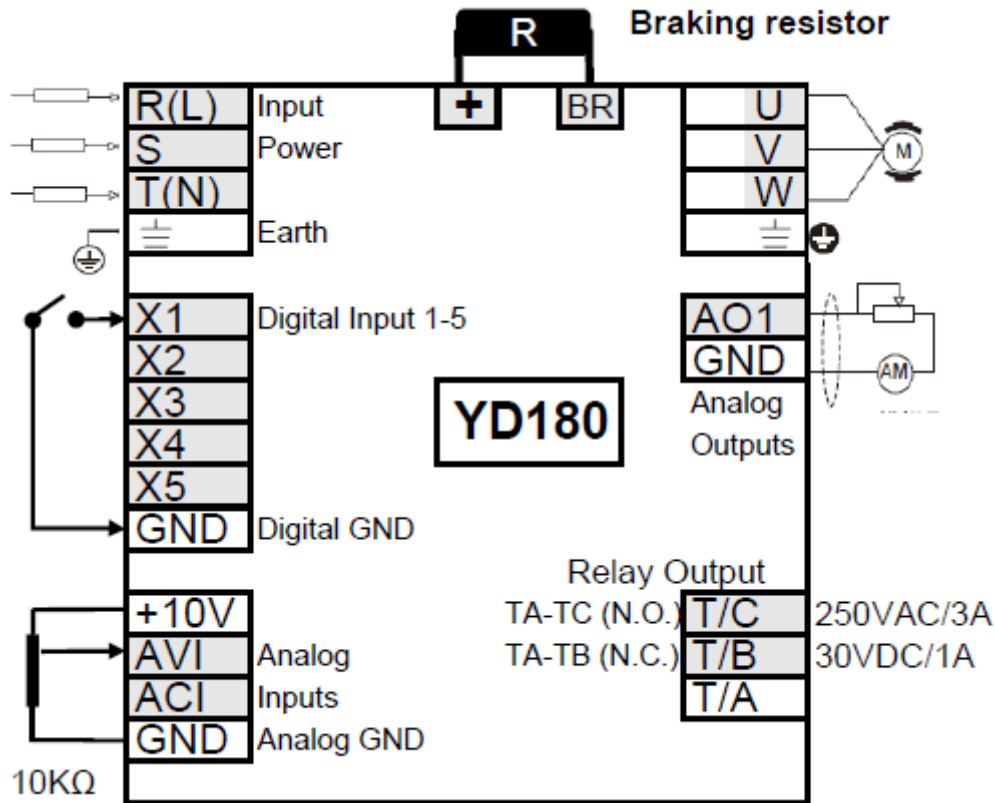

Terminal Name	Use	Setting and Instructions
R、S、T (L、N)	380V model connect R、S、T 220V model connect L、N	The front end uses an air switch overcurrent protection device and a leakage protector. In order to prevent malfunction, a sensitivity of 200 mA or more and an operating time of 100 ms or more are selected.
U、V、W	Output connected to motor	In order to reduce the leakage current, the motor line should not exceed 50 meters.
⊥	earthing	inverter should be well grounded.
+、BR	Brake	Connect the braking resistor
X1	Digital input X1	By parameter P5.02 set, factory default is forward
X2	Digital input X2	By parameter P5.03 set, factory default is reversed
X3	Digital input X3	By parameter P5.04 set, factory default is multi-speed 1
X4	Digital input X4	By parameter P5.05 set, factory default is multi-speed 2
X5	Digital input X5	By parameter P5.06 set, factory default is external fault reset
GND	Signal public points	Zero potential of input and output signals
AVI	Voltage analog input	0-10V
+10V	Potentiometer power supply	+10V , Max 10mA
ACI	Current analog input	0-20mA or 4-20mA
AO1	Analog Output	Function by P6.10 setting; 0-10V
TA、TB、TC	Relay Output	Function by P5.07 setting Contact capacity: AC 250V/3A DC 24V/2A

Adjustments to the panel **keyboard**

① Operation panel and operation method

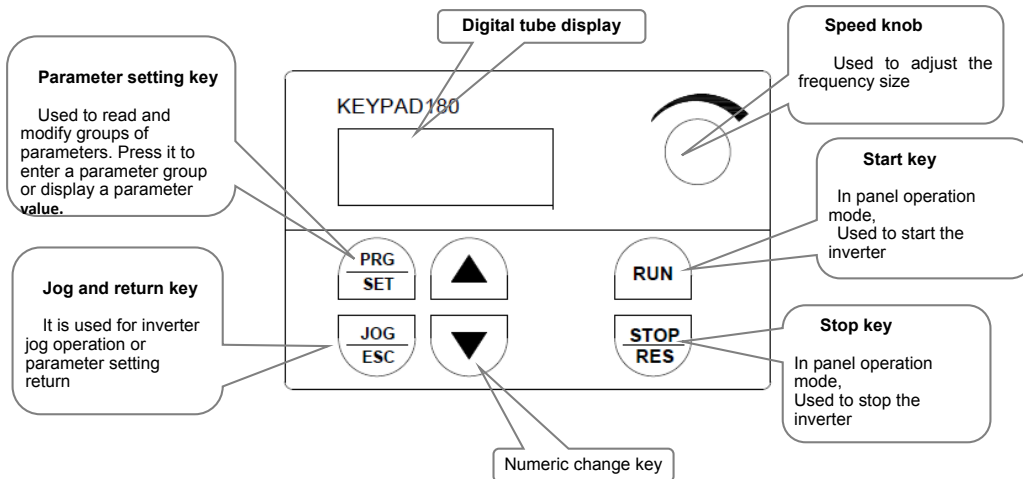

Key	Name	Function Description
PRG/SET	Programming key Setting key	In the case of the zero-level menu (operation interface), the first-level menu, and the second-level menu, press this key to enter the next level menu. In the case of a three-level menu, press this button to set the parameters.
JOG/ESC	Multi-function key (default jog) Return key	In the Level Zero menu (Operation Interface), press this button to switch the selection according to the function set in P4.06. In the case of a first-level, second-level, or third-level menu, this key is used to return to the previous menu.
▲	Increment key	Increment the value of function codes, menu groups, or set parameters.
▼	Decrement key	Decreasing values for function codes, menu groups, or set parameters.
RUN	Run key Shift key	In the zero-level menu (operating interface), it is used to start the inverter. In the second and third level menus, you can change the modification bit of the data you wish to set.
STOP/RES	Stop key Reset key	It is used for the shutdown operation in the running state. It is used for the reset operation in the fault alarm state.

Password Cancellation Before Parameter P Setting (Process 0)

Before modifying or setting the parameters of the P group, before entering the first-level menu each time, you have to do the action of canceling the password, and if you return to the zero level, you have to reset it:

- 1. After powering on, "0000" will be displayed at the next level of the -P0- interface, and the password can be entered to enter the next level menu.
- 2. If you have not set a password before, you can directly press the value to "0001" before you can modify the parameters.

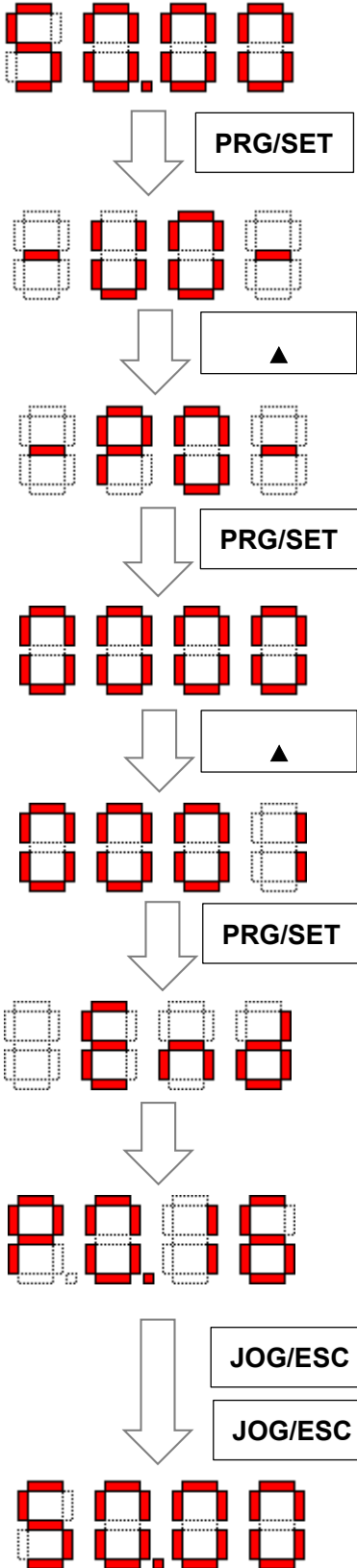

A display of P0.16 indicates that it has been lifted

Go back to level zero menu and have to be re-dismissed

Monitoring Parameters (Process 1)

1. Enter the first-level parameter -U0-
2. Enter the secondary parameter U0.04,
3. Enter the third level to see the current output data,
4. Finally, return to the zero-level interface:

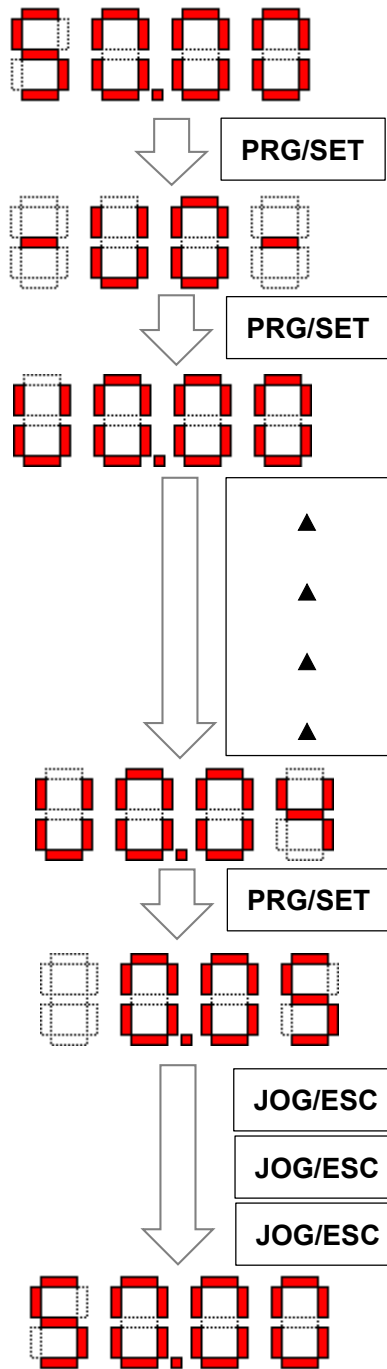

Represents 0.05A

Debugging Parameters (Process 2)

0. Remove the password first (refer to process 0)
1. Enter the first-level parameter-P1-
2. Enter the secondary parameter P1.03,
3. Enter the third stage to modify the carrier frequency to 2Khz,
4. Finally, return to the zero-level interface:

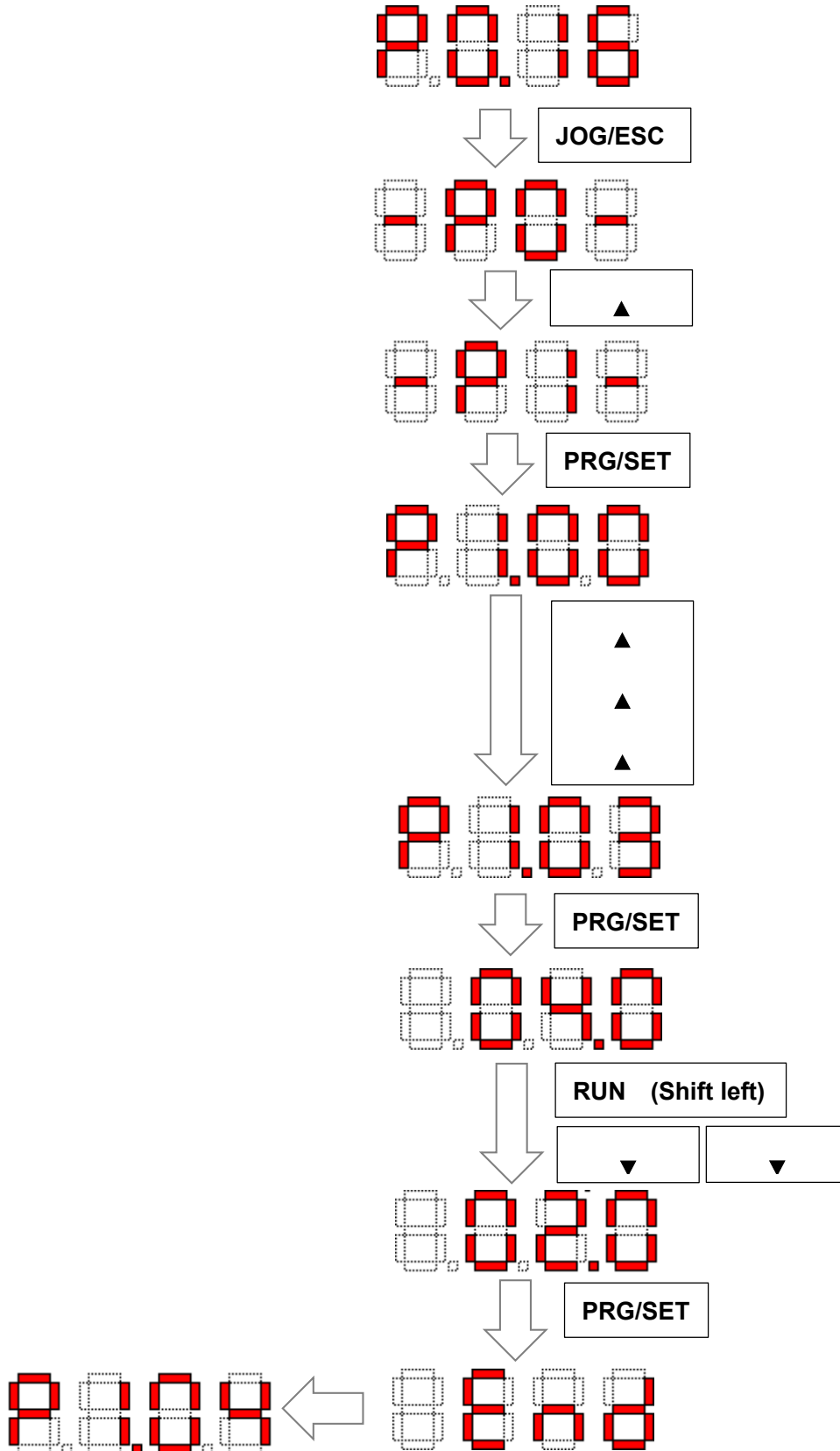

4、Parameters Table

Para	Name	Default	Range of set	Explain
P0 Group - Basic operating parameters				
P0.00	Power Type	Model	0.4-2.2kw	Inverter Power
P0.01	Control Mode	0	0-1	0: V/F 1: Vector (Open loop)
P0.02	Run/Stop command	1	0-1	0: By Panel (Run key & Stop) 1: By Terminal (2 or 3-wire)
P0.03	Main frequency Source X	5	0-7	0: Digital (By P0-07, UP/DOWN, via P0-07 value, Power off does not remember) 1: Digital (By P0-07, UP/DOWN, via P0-07 value, Power off does remember) 2: AVI 3: ACI 4: Potentiometer 5: Multi-Speed commands 6: Simple PLC 7: PID
P0.04	Aux frequency source Y	0	0-7	Same P0.03
P0.05	Main and Aux frequency operations	0	0-3	0: Main + Aux 1: Main - Aux 2: Max(Main, Aux) 3: Min(Main, Aux)
P0.06	Frequency source selection	0	0-4	0: Main X (P0.03) 1: Operation (P0.05) 2: Switch by Main(P0.03) and Aux(P0.04) 3: Switch by Main(P0.03) and Operation(P0.05) 4: Switch by Aux(P0.04) and Operation(P0.05) ▲Note:Switch via terminal(X1-X5) and set 18
P0.07	Freq of Preset	12.50Hz	0 - Max.Freq(P0.08)	This setpoint is the initial value given by the frequency number
P0.08	Max Frequency	50.00Hz	Upper Freq(P0.09) -400.0Hz	Max frequency is the highest allowable output frequency of inverter, which is the benchmark for acceleration and deceleration settings.
P0.09	Upper Frequency	50.00Hz	Lower Freq(P0.10)- Max Freq(P0.08)	The operating frequency cannot exceed this frequency
P0.10	Lower Frequency	0.00Hz	0-Upper Freq(P0.09)	The operating frequency cannot be lower than that
P0.11	Below P0.10 Processing	0	0-2	0: Running at zero speed 1: Operates at P0.10 2: Downtime(Stop)
P0.12	First acceleration time	5.0s	0.1~6500.0s	The time required to accelerate from zero to the maximum frequency (P0.08).
P0.13	First deceleration time	2.2s	0.1~6500.0s	The time required to decelerate from the maximum frequency (P0.08) to zero
P0.14	Direction of operation	0	0-2	0: Forward rotation, 1: Reverse, 2: Reverse reversal is prohibited P0.14 is valid when forward and reverse parameters are selected to run the command from the panel. If reverse is prohibited, inverter will not be reversed regardless of the source of the running command.
P0.15	User password	0	0~9999	Set a password, display "0000" at the next level of the "-P0-" interface, and you need to enter the password to enter the next level menu; When a non-zero number is set, the password takes effect; If 0000 is set to decryption, the password function will be disabled.
P0.16	Soft version	xx.xx	01.00-99.99	Current software version.
P0.17	Parameter initialization	0	0-3	0: No operation 1: Restore factory value (excluding motor parameters) 2: The fault is cleared 3: All parameters are restored to factory values (including motor parameters)
P0.19	Frequency Decimal point	2	1~2	1:0.1Hz (frequency can be set up to 4000Hz) 2: 0.01Hz (frequency can be set up to 400.0Hz)
P0.20	Digital settings Downtime holds	1	0~1	0: Not retentive 1: Retentive
P1 group - V/F control parameters				
P1.00	V/F curve setting	0	0-6	0: Linear curve 1: square curve 2: 1.5 power curve 3: 1.2 power curve 4: Multi-point VF curve 5: VF completely separation 6: VF semi-separation
P1.01	Torque Boost	Model	0.0~30.0%	Manual torque lift This value setting is a percentage relative to the rated voltage of the motor. When it is 0, switch to automatic torque boost.
P1.02	Torque boost Cut-off frequency	50.00Hz	0.0~50.00Hz	The point at which the manual torque is lifted off at the cut-off frequency
P1.03	Carrier frequency setting	Model	2.0~16.0KHz	Increasing the carrier frequency can reduce noise, but increasing the carrier frequency will increase the heat generation of the inverter.
P1.04	V/F frequency value F1	12.50Hz	0.01~F2(P1.06)	
P1.05	V/F voltage value V1	25.0%	0.0~V2(P1.07)	
P1.06	V/F frequency value F2	25.00Hz	F1(P1.04)~ F3(P1.08)	
P1.07	V/F voltage value V2	50.0%	V1(P1.05)~ V3(P1.09)	
P1.08	V/F frequency value F3	37.50Hz	F2(P1.06)~ Motor rate freq(P9.04)	
P1.09	V/F voltage value V3	75.0%	V2(P1.07)~100.0% Motor rate volt(P9.01)	

Para	Name	Deafult	Range of set	Explain
P1.10	Torque boost mode	7	0~7	
P1.11	Braking rate	90%	0~100%	Braking resistance, braking rate
P1.12	Torque compensation gain	100%	0~300%	
P1.13	VF Over-excitation gain	Model	0~200%	
P1.14	Oscillation suppression mode	3	0~3	In V/F mode, most motors will be speed and current oscillation at low frequency, and the oscillation may cause the inverter to overcurrent. Enables which can eliminate oscillation. 0: invalid 3: Valid
P1.15	VF detached voltage source	0	0~9	0: Digital given (P1.16) 1: AVI 2: ACI 3: Keyboard potentiometer 5: Multi-step speed 6: PLC 7: PID 9: Current closed loop
P1.16	Digital setting of voltage source for VF separation	0	0~ Motor rated voltage	
P1.17	Voltage rise time of VF separation	0.0	0.0~1000.0	
P1.18	Voltage deceleration time for VF separation	0.0	0.0~1000.0	
P1.19	VF detached and shut down Method selection	0	0~1	0: Stops according to P3.05 1: The voltage is reduced to 0 and the frequency is reduced again
P1.20	VF separation current closed-loop control setpoint	100	0~Current limiting level	
P2 group - vector control parameters				
P2.00	Speed loop low speed Kp	20	1~100	
P2.01	Speed loop low speed Ki	0.50	1~10.00	
P2.02	Speed ring high-speed Kp	10	1~100	
P2.03	Speed ring high-speed Ki	1.00	1~10.00	
P2.04	Speed loop low-speed frequency calculates the switching point	10.00Hz	Lower Limit Frequency ~ Maximum frequency	
P2.05	Speed loop high-speed frequency calculates the switching point	30.00Hz	Lower Limit Frequency ~ Maximum frequency	
P2.06	Motorized slip compensation gain	0%	0~200.0%	
P2.10	Current loop Kp	2000	0~6000	
P2.11	Current loop Ki	1300	0~6000	
P2.14	Open-loop vector slip compensation gain	100%	0~200%	
P2.19	Speed control (drive) torque upper limit digital setting	150.0%	0~200.0%	
P2.20	Maximum moment coefficient in the weak magnetic field	100%	50~200%	
P2.21	M-axis current loop proportionality factor	5	5~300	
P2.22	M-axis current loop integration coefficient	0	0~6553	
P2.23	Open-loop vector velocity loop filtering time constant	0.25	0~1.00	
P2.24	Open-loop vector torque boost	100	0~500	
P2.25	The open-loop vector torque increases the cut-off frequency	20.00Hz	Lower Limit Frequency ~ Maximum frequency	
P2.26	Torque is given to the filter	28	0~31	
P2.27	Maximum overmodulation coefficient of weak	105%	0~120%	

Para	Name	Default	Range of set	Explain
	magnetic voltage			
P2.28	Compensation coefficient for magnetic flux observations	100%	0~200%	
P2.29	Magnetic flux observation filter coefficient	300	0~2000	
P2.30	T-axis current closed-loop coefficient	0	0~500	
P2.31	Torque limiting method	1	0~1	
Group P3 - Auxiliary Running Parameters				
P3.00	Startup mode	0	0-1	0: Started by the start frequency 1: After DC braking, it is started by the starting frequency
P3.01	Startup frequency	0.50Hz	0.50~20.00Hz	The initial frequency at which the drive starts
P3.02	Startup frequency hold time	0	0.0~60.0s	Start frequency, run time
P3.03	Activates the DC brake current	0.0%	0.0~100%	The current value at which DC braking is applied When the rated current of the motor is less than or equal to 80% of the rated current of the inverter, the rated current of the relative motor is the percentage base value; When the rated current of the motor is greater than 80% of the rated current of the inverter, it is the percentage base value of the rated current of the inverter relative to 80%.
P3.04	Start DC braking time	0.0s	0.0~60.0s	The duration of the DC brake applied
P3.05	Downtime mode	1	0~2	0: deceleration and shutdown, 1: Deceleration and shutdown + DC braking 2: Free shutdown
P3.06	Shutdown DC braking start frequency	12.40Hz	0.00~Upper limit frequency	The frequency reaches the preset frequency and starts DC braking
P3.07	Shutdown DC braking current	20.0%	0.0~100%	The current value of applying DC braking is the same as activating DC braking
P3.08	Downtime DC braking time	1.0s	0.0~30.0s	The duration of the DC brake applied
P3.16	STOP/RESET key function	1	0-1	0: Stateless 1: Enabled in any situation
Group P4 - Auxiliary Running Parameter 2				
P4.00	Forward jog frequency setting	10.00Hz	0.00~50.00Hz	Set the jog forward and reverse frequency
P4.01	Reverses jog frequency setting			
P4.02	Jog acceleration time	Model	0.1~999.9s	Set the jog acceleration and deceleration time
P4.03	Jog deceleration time			
P4.04	Second acceleration time	10.0s	0.1~999.9s	
P4.05	Second deceleration time	10.0s	0.1~999.9s	
P4.06	Multi-function buttons	1	0~3	0: jog operation; 1: Jog run, with the highest priority 2: The current motor direction is reversed; 3: Forward and reverse switching;
P4.07	Jump frequency	0.00Hz	0.0~Upper.Freq	By setting the jump frequency and range, the inverter can avoid the mechanical resonance point of the load.
P4.08	Jump range	0.00Hz	0.0~10.0Hz	
P4.09	Jump frequency 2	0.00Hz	0.0~Upper.Freq	
P4.10	Jump range 2	0.00Hz	0.0~10.0Hz	
P4.11	Jump frequency 3	0.00Hz	0.0~Upper.Freq	
P4.12	Jump range 3	0.00Hz	0.0~10.0Hz	
P4.13	Jump frequency 4	0.00Hz	0.0~Upper.Freq	
P4.14	Jump range 4	0.00Hz	0.0~10.0Hz	
P5 Group - Digital I/O parameters				
P5.00	FWD/REV terminal control mode	0	0-3	0: 2-wire control mode 1 1: 2-wire control mode 2 2: 3-wire control mode 1 3: 3-wire control mode 2
P5.01	Terminal function detection when powering on	0	0-1	0: The terminal command is invalid when the power is on 1: The terminal command is valid when the power is on
P5.02	Input terminal X1 function	3	0~30	0: No function 1: Forward jog control 2: Reverse jog control 3: Forward Control (FWD) 4: Reverse Control (REV) 5: 3-wire operation control 6: Free shutdown control 7: External shutdown signal input (STOP) 8: External Reset Signal Input (RST) 9: External Normally open faults input (Fault) 10: Frequency Increment Command (UP) 11: Frequency Decreasing Command (DOWN) 12: Select S1 for multi-stage speed 13: Select S2 for multi-stage speed 14: Select S3 for multi-stage speed 15: Run the command channel to force the terminal
P5.03	Input terminal X2 function	4	0~30	
P5.04	Input terminal X3 function	12	0~30	
P5.05	Input terminal X4 function	13	0~30	
P5.06	Input terminal X5 function	8	0~30	

Para	Name	Default	Range of set	Explain
				17: Shutdown DC Braking Command 18: Frequency Source Switching (P0.06) 22: Counter Clearing Signal (Pb.10 Counting Function) 23: Counter trigger signal (Pb.10 counting function) 24: Timer zero signal (Pb.10 timing function) 25: Timer trigger signal (Pb.10 timing function) 26: Acceleration and deceleration time selection (acceleration and deceleration time 1 and acceleration and deceleration time 2 switch selection) 29: Shutdown control (need to re-give the run command) 30: Forward and reverse switching
P5.07	Relay R output function setting	5	0~14	0: No function 1: The inverter is ready for operation 2: The inverter is running 3: The inverter is running at zero speed 4: External fault shutdown 5: Inverter failure 6: Frequency/Velocity Arrival Signal (FAR) 7: Frequency/Velocity Level Detection Signal (FDT) 8: The output frequency reaches the upper limit 9: The output frequency reaches the lower limit 10: Inverter overload pre-alarm 11: Timer overflow signal (relay output when the timing time reaches the timing setting time of Pb.13) 12: Counter detection signal (relay output when the counting value reaches the counter detection value of Pb.12) 13: Counter Reset Signal (Reserved) 14: Reserved
P5.08	R closure delay	0.0s	0.0~999.9s	The delay between the change of the R state of the relay and the change of output
P5.09	R disconnect time			
P5.10	The frequency reaches the FAR detection amplitude	5.00Hz	0.00Hz~15.00Hz	The output frequency is within the positive and negative detection width of the set frequency, and the terminal outputs a valid signal (low level).
P5.11	FDT Horizontal setpoint	10.00Hz	0.00Hz~ Upper Freq	
P5.12	FDT Hysteresis value	1.00Hz	0.00~30.00Hz	
P5.13	UF/DOWN Terminal modification rate	1.00Hz/s	0.10Hz~200.00Hz/s	Set the frequency modification rate when the UP/DOWN terminal is set at a frequency, that is, the amount of frequency change when the UP/DOWN terminal is shorted with the COM terminal for one second.
P5.14	Keep			
P5.15	Input terminal effective logic setting (X1~X5)	0	0~31	Bit0 ~ Bit4 corresponds to X1 ~ X5 respectively 0: indicates positive logic. that is, the communication between the Xi terminal and the common terminal is valid, but the disconnection is invalid 1: indicates anti-logic, that is, the communication between the Xi terminal and the common terminal is invalid, and the disconnection is valid
P5.16	X1 Filtering coefficient	5	0~9999	Used to set the sensitivity of the input terminal. If the digital input terminal is susceptible to interference and malfunctions, this parameter can be increased to increase the anti- interference ability, but setting too large will reduce the sensitivity of the input terminal. 1: represents the unit of 2ms scanning time
P5.17	X2 Filtering coefficient	5	0~9999	
P5.18	X3 Filtering coefficient	5	0~9999	
P5.19	X4 Filtering coefficient	5	0~9999	
P5.20	X5 Filtering coefficient	5	0~9999	
P6 group - analog input and output function				
P6.00	AVI input lower limit voltage	0%	0.0~120.0%	Set the lower AVI voltage
P6.01	AVI input upper limit voltage	100.0%	0.0~120.0%	Set the upper AVI voltage
P6.02	AVI lower limit is set accordingly	0.0%	-100.0%~120.0%	Set the AVI lower limit corresponding to the setting, which corresponds to the percentage of the maximum frequency.
P6.03	AVI upper limit is set accordingly	100.0%	-100.0%~120.0%	Set the AVI upper limit corresponding to the setting, which corresponds to the percentage of the maximum frequency.
P6.04	ACI input lower limit current	0.0%	0.0~120.0%	Set the lower ACI current ▲ 0-20mA(P6-04=0.00%) / 4-20mA(P6-04=20.0%)
P6.05	ACI input upper limit current	100.0%	0.0~120.0%	Set the upper ACI current
P6.06	ACI lower limit is set accordingly	0.0%	-100.0%~120.0%	Set the ACI lower limit corresponding to the setting, which corresponds to the percentage of the maximum frequency.
P6.07	ACI upper limit is set accordingly	100.0%	-100.0%~120.0%	Set the ACI upper limit corresponding to the setting, which corresponds to the percentage of the maximum frequency.
P6.08	Analog input signal filtering time constant	0.1s	0.1~5.0s	This parameter is used to filter the input signals of the AVI, ACI, and panel potentiometers to eliminate the effects of interference.
P6.09	Analog input stabilization deviation limit	0	0.00~100.0%	When the analog input signal fluctuates frequently around a given value, the frequency fluctuation caused by this fluctuation can be suppressed by setting this parameter.
P6.10	AO1 analog output terminal function selection	0	0~5	0: Output frequency, 0~maximum frequency 1: Set frequency, 0~maximum frequency 2: Output current, 0~2 times rated current 3: Output voltage, 0~2 times the rated voltage 4: AVI, 0~10V 5: ACI, 0~20mA
P6.11	AO1 Functional Minimum Limit	0.0	0.0~120.0%	Set the upper and lower limits of the AO function
P6.12	AO1 Functional Maximum Limit	100.0%		

Para	Name	Deafult	Range of set	Explain
P6.13	AO1 Output Minimum Limit	0.0		Set the upper and lower AO output limits
P6.14	AO1 Output Maximum Limit	100.0%		
P6.15	The panel potentiometer input lower limit voltage	10.9%	0.0~120.0%	Set the lower limit voltage of the panel potentiometer
P6.16	The panel potentiometer input upper limit voltage	96.0%	0.0~100.0%	Set the upper limit voltage of the panel potentiometer
P6.17	The lower limit of the panel potentiometer is set accordingly	0.0%	-100.0%~120.0%	Set the lower limit of the panel potentiometer to be set as a percentage of the maximum frequency.
P6.18	The upper limit of the panel potentiometer is set accordingly	100.0%	-100.0%~100.0%	Set the upper limit of the panel potentiometer to be set as a percentage of the maximum frequency.
P6.19	Panel potentiometer stabilization deviation limit	3.5%	0.00~100.0%	When the panel potentiometer fluctuates frequently around a given value, the frequency fluctuations caused by this fluctuation can be suppressed by setting this parameter.
P6.20	Panel potentiometer filtering time constant	0.1s	0.1~5.0s	This parameter is used to filter the input signal of the panel potentiometer to eliminate the effects of interference.
P7 Group - Program Running Parameters (PLC)				
P7.00	Multi-speed frequency 1	5.00Hz	Lower Limit Freq ~ Upper Limit Freq	Set the frequency of Multi-speed 1
P7.01	Multi-speed frequency 2	10.00Hz	Lower Limit Freq ~ Upper Limit Freq	Set the frequency of Multi-speed 2
P7.02	Multi-speed frequency 3	15.00Hz	Lower Limit Freq ~ Upper Limit Freq	Set the frequency of Multi-speed 3
P7.03	Multi-speed frequency 4	20.00Hz	Lower Limit Freq ~ Upper Limit Freq	Set the frequency of Multi-speed 4
P7.04	Multi-speed frequency 5	25.00Hz	Lower Limit Freq ~ Upper Limit Freq	Set the frequency of Multi-speed 5
P7.05	Multi-speed frequency 6	37.50Hz	Lower Limit Freq ~ Upper Limit Freq	Set the frequency of Multi-speed 6
P7.06	Multi-speed frequency 7	50.00Hz	Lower Limit Freq ~ Upper Limit Freq	Set the frequency of Multi-speed 7
P7.07	Programmable operation control (simple PLC operation)	0	0~2	0: Single cycle 1: Continuous cycle 2: Maintain the final value after a single cycle
P7.08	Downtime memory selection	0	0~1	0: Downtime does not remember 1: Downtime memory
P7.09	Power-down memory selection	0	0~1	0: Power off does not remember 1: Power off remember
P7.10	T1 run time	10.0s	0.0~999.9s	Set the run time of section speed 1
P7.11	T2 run time	10.0s	0.0~999.9s	Set the run time of section speed 2
P7.12	T3 run time	10.0s	0.0~999.9s	Set the run time of section speed 3
P7.13	T4 run time	10.0s	0.0~999.9s	Set the run time of section speed 4
P7.14	T5 run time	10.0s	0.0~999.9s	Set the run time of section speed 5
P7.15	T6 run time	10.0s	0.0~999.9s	Set the run time of section speed 6
P7.16	T7 run time	10.0s	0.0~999.9s	Set the run time of section speed 7
P7.17	T1 run mode	0	0~3	0: Forward, select acceleration time 1 1: Forward, select acceleration time 2 2: Reverse, select acceleration time 1 3: Reverse, select acceleration time 2
P7.18	T2 run mode	0		
P7.19	T3 run mode	0		
P7.20	T4 run mode	0		
P7.21	T5 run mode	0		
P7.22	T6 run mode	0		
P7.23	T7 run mode	0		
P7.26	Multi-stage speed priority	1	0~1	0: Not a priority 1: Priority, priority is lower than jog
P8 group - PID parameters				
P8.00	PID control features	0	0~1	0: Positive 1: Negative
P8.01	PID given selection	0	0~3	0: Numeric setting 1: Keyboard potentiometer setting 2: AVI input 3: ACI input
P8.02	PID feedback selection	0	0~1	0: AVI 1: ACI
P8.03	PID digital setting	3.0	The lower limit of PID range ~ The upper limit of PID range	The given value of the PID when the source is set to a number
P8.04	PID acceleration and deceleration time	0.0	0.00~100.0s	
P8.05	PID bias setting	0.0	0 ~100.0%	
P8.06	PID bias hold time	0.0	0 ~6000.0s	

Para	Name	Deafult	Range of set	Explain
P8.07	Upper limit of PID deviation	100.0	0 ~ 100.0%	
P8.08	Lower limit of PID deviation	0.0	00.0%~ 100.0% (Max frequency)	
P8.09	Proportional gain	5.00	0.00~600.00	
P8.10	Integration time	2.0	0:No Ki 0.1~100.0s	
P8.11	Differential time	0.00	0.00:No Kd 0.00~10.00s	
P8.12	Upper limit of PID output	100.0	0.0~100.0%	
P8.13	Lower limit of PID output	0.0	0.0~100.0%	
P8.14	PID output filtering time	0.00	0.00~10.00s	
P8.15	Feedback fault action selection	2	0~4	0: Runs at the upper frequency limit 1: Operate at the lower frequency limit 2: Operate at a digitally set frequency 3: Stop at deceleration time 4: Free parking
P8.16	Loss of detected values	0.0	0.0~100.0%	
P8.17	Loss of detection time	1.0	0.0~100.0s	
P8.18	exceed of detected values	100.0	0.0~100.0%	
P8.19	exceed of detection time	1.0	0.0~100.0s	
P8.20	PID sleep control	0	0~2	0: No sleep function 1: Internal wake-up 2: External input terminal control
P8.21	Sleep shutdown mode	0	0~1	0: Decelerates to stop 1: Free shutdown
P8.22	Sleep frequency	0.00	0.00 Hz ~ Max frequency	
P8.23	Sleep pressure	95.0%	P8.25 ~100.0%	
P8.24	Sleep delay time	30.0	0.0~6000.0s	
P8.25	Wake up pressure	80.0%	0.0%~P8.23	
P8.26	Wake up delay time	3.0	0.0~60.0s	
P8.27	Lower PID range	0.0	-3276.8~ 3276.8	Since the display is 4 digital tubes, the number of digits displayed may not match the actual value, but it does not affect the final set value.
P8.28	Upper PID range	10.0	-3276.8~ 3276.8	Since the display is 4 digital tubes, the number of digits displayed may not match the actual value, but it does not affect the final set value.
P8.29	The number of decimal places in the range	1	0~3	0: No decimal point is displayed 1: Displays one decimal point 2: Displays two decimal point 3: Displays three decimal point This parameter is only used to control the display of the number of decimal places in P8.03, P8.25, P8.26, U0-11 and U0-12.
P8.30	Frequency pressure in case of water shortage	48.00Hz	0.00Hz~ Max.Frequency	
P8.31	Detection pressure in case of water shortage	0.0	0.0~P8.28	
P8.32	Detection time in case of water shortage	60.0s	0~6500.0s	
P8.33	Restart time in case of water shortage	600.0s	0~6500.0s	
P8.34	Number of restarts in case of water shortage	6	9999	
P8.36	Water pump operation mode	0	0~2	0: Disabled 1: Pump operation mode 1 2: Pump operation mode 2
P8.37	MPPT low point operating voltage	Model	0~ P8.38	If bus voltage (U-03) is higher than the value of MPPT high point working voltage (P8.38), it will run at the maximum frequency; If it is lower than the MPPT high point working voltage (P8.38) set value, it will be operated at the frequency obtained by the maximum frequency of (bus voltage/MPPT high point working voltage)*, and if the bus voltage reaches the MPPT low point working voltage (P8.37), it will be operated at the lowest operating frequency of the water outlet (P8.44).
P8.38	MPPT high point operating voltage	Moel	P8.37~1000V	
P8.39	Fault shielding in case of water shortage	0	0~1	0: No shielding 1: Shielding
P8.40	Restart enable when undervoltage	0	0~1	0: Disabled 1: Enabled
P8.41	Restart delay when undervoltage	10.0s	0.0s~ 360.0s	The delay time is timed from the beginning of the undervoltage
P8.42	Self-starting	0	0~3	0: Not enabled; 1: Power-on auto-start enabled; 2: After the fault is reset, it will be enabled auto-starting; Note: If the preceding two functions are enabled, set to the sum of the two values, that is, 3.

Para	Name	Default	Range of set	Explain
P8.43	The detection current value of the pump when there is a shortage of water corresponds to the proportion of the no-load current	0.0	0.0~300.0%	If the operating frequency of the inverter is above (P8.44) and the output current is less than the no-load current of the motor (P9.11)*(P8.43), after the (P8.45) time has passed, the inverter will report a water shortage fault ELT.
P8.44	The minimum frequency at which the pump is running out of water	0.00	0~99.99Hz	
P8.45	The detection time when the pump is running out of water	0.0	0~250.0s	
P8.46	Swing frequency control	0	0~1	0: invalid 1: Valid
P8.47	Swing method	0	0~1	0: fixed swing amplitude; Swing reference value is the maximum output frequency (P0.08). 1: Variable swing amplitude; Swing reference value is for a given channel frequency.
P8.48	Selection of the start-up mode after the swing frequency shutdown	1	0~1	0: Start according to the state remembered before stopping 1: Start again
P8.49	Swing Amplitude	0.0%	0.0%~100.0%	The swing amplitude is relative to the maximum output frequency (P0.08).
P8.50	Frequency of bounces	0.0%	0.0%~50.0%	In the process of balance frequency, the amplitude of the rapid decline of the frequency when the frequency reaches the upper limit of the pendulum frequency, the amplitude of the rapid rise of the frequency after the frequency reaches the lower limit of the pendulum frequency. This value is a percentage relative to the amplitude of the pendulum (P8.49), 0.0% has no bounce frequency.
P8.51	Swing rise time	5.0s	0.1s~400.0s	When the swing frequency is running, the elapsed time when the lower limit frequency reaches the upper frequency.
P8.52	Swing drop time	5.0s	0.1s~400.0s	When the swing frequency is running, the elapsed time when the upper limit frequency reaches the lower frequency.
P8.53	Delay of upper limit frequency of swing frequency	5.0s	0.1s~999.9s	Set the upper and lower limits of swing frequency delay.
P8.54	Delay of lower limit frequency of swing frequency	5.0s	0.1s~999.9s	
Group P9 - Motor parameter setting				
P9.00	Rated Power	Model		Motor parameter settings
P9.01	Rated Voltage	Model	1~500V	Motor parameter settings
P9.02	Rated Current	Model	0.01~99.99A	
P9.03	Rated Speed	Model	0~60000rpm	
P9.04	Rated Frequency	50.0Hz	1.0~400.00Hz	Operating frequency cannot exceed 8 times the rated frequency. For example, to run 400Hz, the rated frequency P9.04 needs to be > 50.00Hz
P9.05	Parameter identification	0	0~1	0: parameter identification is not enabled. 1: Enable static parameter identification, and automatically set 0 when the identification is completed;
P9.06	Stator Resistance	Model	0.001~65.535Ω	Different models have corresponding default values, and parameter identification will automatically change the values;
P9.07 ~ P9.09	Rotor resistance, leakage inductance, mutual inductance, etc	Model		Different models have corresponding default values, and parameter identification will automatically change the values;
P9.11	No-load current	Model	0.01~	Set the no-load current of the motor; Different models have corresponding default values, and parameter identification will automatically change the values;
P9.12	Motor speed unit	1	1~2	1: 1rpm 2: 10rpm
PA Group - Protection Parameter Setting				
PA.00	Overload protection	00	0000~9999	Single digit: motor overload (OL1) enabled Ten digit: Inverter overload (OL2) warning enabled (1: terminal function output, inverter overload warning enabled); (2: terminal function output, report fault shutdown)
PA.01	Motor overload protection factor	100%	30%~110%	The motor overload protection coefficient is the percentage of the rated current value of the motor to the rated output current value of the inverter
PA.02	Undervoltage protection level	180/360V	150~280V 250~480V	When the inverter is working normally, the lower limit voltage allowed by the DC bus.
PA.03	Overvoltage stall enabled	1	0~1	0: Disabled 1: Enable
PA.04	Overvoltage limit level	375/720V	350~380 660~790V	The operating voltage at the time of overvoltage stall protection
PA.05	Current limiting level	150%	30%~200%	The current threshold for limiting the current action, the set value of which is the percentage of the rated current relative to the inverter.
PA.06	The rate of frequency drop when the current is limited	0	0~99.99Hz/s	The slope of the frequency drop when current limiting occurs. The default value is 0.0Hz, which means that the current frequency value is maintained.
PA.07	Current limiting action selection	0	0~2	0: invalid 1: Acceleration and deceleration are effective, constant speed is invalid 2: Acceleration and deceleration are effective, and constant speed is effective
PA.08	The inverter is overloaded Predictive alarm level	120%	30~150%	The current threshold of the overload pre-alarm action of the inverter is set as a percentage of the rated current of the inverter.

Para	Name	Default	Range of set	Explain
PA.09	Inverter Overloaded Pre-alarm delay	5.0s	0.0~60.0s	The delay time between the output current of the inverter that is continuously greater than the overload pre-warning (PA.08) and the output of the overload pre-warning signal.
PA.10	Oscillation suppression coefficient	30	0~100	In general, when the motor oscillates, the oscillation suppression coefficient is increased.
PA.11	Amplitude suppression coefficient	20	0~1000	Sets the maximum amount of adjustment for oscillation rejection
PA.12	Oscillation suppresses the upper limit frequency	5.00Hz	0.0~PA.12(200.00Hz)	Below this frequency, oscillation suppression is ineffective.
PA.13	Oscillation suppresses the lower limit frequency	50.00Hz	PA.13(0.00)~200.00Hz	Above this frequency, oscillation suppression is ineffective.
PA.16	Number of times the fault is automatically reset	0	0~30	When the number of resets is set to 0, there is no automatic reset function, and only manual reset can be made.
PA.17	The interval time between fault auto-reset	3.0s	0.5~25.0s	Set the time between fault auto-resets
PA.18	VF over-current and over-voltage suppression enabled	3	0~3	0: No operation 1: Overcurrent suppression is enabled 2: Overvoltage suppression enabled 3: Over-current and over-voltage suppression enabled
PA.19	VF overcurrent suppresses Kp	20	0~100	
PA.20	VF over-velocity and velocity loss action current compensation coefficient	50	50~200	
PA.21	VF overvoltage suppresses Kp	60	0~100	
PA.22	The maximum frequency of VF overvoltage stall rise	5	0~50	
PA.23	VF overvoltage stall voltage regulation Kp	80	0~100	
PA.24	Power-down and under-voltage shutdown mode	0	0~1	0: Report under-voltage fault, free stop; 1: Do not report the under-voltage fault, and stop according to the set parking mode (P3.05).
PA.25	Fan Control (Compatible with Some Models)	1	0~1	0: Fan starts to rotate when the power is on, and the fan stops running when the power is off; 1: Fan starts to rotate when inverter is running, and the fan stops after inverter stops for 12s
PA.26	Output phase-loss enabled	1	0~1	0: The output phase loss protection is disabled 1: The output phase loss protection is enabled
PA.27	DC braking voltage	220V:370 380V:670	By Model 350~790	
PA.40	Limit current and reduce frequency Settings	0	0~6553	1: Enable frequency drop operation when current is limited; 2: Enable frequency drop operation when voltage is lower; 4: keep; 8: Input phase-out enabled; Note: If multiple functions are enabled, set the sum of the corresponding function values.
PA.41	Limit current and reduce frequency level	100.0%	0~180.0%	This parameter is calculated based on the motor current (P9.02). (PA.41 * P9.02) = Current limit and frequency reduction point
PA.42	The size of the window current that limits current and reduces frequency	1.0%	0.0~100.0%	Calculated as a percentage of motor current
PA.43	The amount of frequency reduction per step	0.05	0.01~50.00	
PA.44	The maximum amount that limits current and reduces frequency	50.0%	0.0~100.0%	Calculated as a percentage of motor current
PA.45	Input phase loss detect value	40	0~1000	
PA.46	Keep			
PA.47	Keep			
PA.48	The gain value of the reduced frequency at low voltage	2048	0~4096	
PB group - display and special parameter settings				
Pb.00	Run monitoring parameters	0	0~15	The default display items on the main monitoring interface. The corresponding number is the U group parameter
Pb.01	Stop monitoring parameters	1	0~15	The default display items on the main monitoring interface. The corresponding number is the U group parameter
Pb.02	Motor speed Display coefficient	1.00	0.01~99.99	It is used to correct the display error of the speed scale, and has no effect on the actual speed.
Pb.03	Current failure	0	0~9999	Current fault code
Pb.04	Previous failure	0	0~9999	Previous Failure Code

Para	Name	Default	Range of set	Explain
Pb.05	The first two failures	0	0~9999	The first two fault codes
Pb.06	Fault voltage	0	0~9999	Bus voltage at the time of failure
Pb.07	Fault current	0	0~999.9	Output current at the time of failure
Pb.08	Fault set frequency	0	0~300.0	Setting frequency at the time of failure
Pb.09	Fault run frequency	0	0~300.0	Running frequency at the time of failure
Pb.10	Counting and timing modes	103	000~304	Single digits: count arrival processing, 0: Single-week counting, stop output, 1: Single-week counting, continue output, 2: Cycle counting, stop output, 3: Cycle counting, continue output. Ten digits: reserved Hundreds: Scheduled arrival processing, 0: Single-week timing, stop output, 1: Single-week timing, continue output, 2: Cycle timer, stop output, 3: Cycle timer, continue output. Thousands: Reserved
Pb.11	Counter reset value setting	1	0~9999	Set the counter reset value
Pb.12	Counter detection value setting	1	0~9999	Set the counter detection value
Pb.13	Timer setting	0	0~9999s	Set a timer
Pb.20	Software Upgrade Date (Years)			
Pb.21	Software Upgrade Date (Month, Day)			
Pb.22	Displays the software version	00. 05		
Pb.23	Product series	320		
Pb.24	Stop and run assist display (valid only for dual display)	4	0~15	The default display items on the main monitoring interface. The corresponding number is the U group parameter
PP group - manufacturer parameter setting				
PP.00	Manufacturer password		1~9999	The system sets a dedicated password

U Group - The monitoring parameter group				
PARA	NAME	RANGE	Min Unit	
U0.00	Output Frequency (Hz)	0.00~400.00Hz	0.01Hz	
U0.01	Set Frequency (Hz)	0.00~400.00Hz	0.01Hz	
U0.02	Output Voltage (V)	0~999V	1V	
U0.03	DC Bus Voltage (V)	0~999V	1V	
U0.04	Output Current(A)	0.00~999.9A	0.01A	
U0.05	Motor speed (Krpm)	0~60000Krpm	1Krpm	
U0.06	Analog Input AV1 (V)	0.00~10.00V	0.01V	
U0.07	Analog Input AC1 (mA)	0.00~20.00mA	0.01mA	
U0.08	Analog Output AO(V)	0.00~10.00V	0.01V	
U0.09	Terminal status (Relay, X1-X5)	0~3FH	1H ex:(3FH=111111B=Relay,X1,X2,X3,X4,X5,ALL ON)	
U0.10	temperature	0~9999	0.1°C	
U0.11	PID given value	PID Range Lower limit ~ PID Range Upper limit	1	
U0.12	PID feedback value	PID Range Lower limit ~ PID Range Upper limit	1	
U0.13	Current Count Value(s)	0~9999	1s	
U0.14	Current Timing Value(s)	0~9999s	1s	
U0.15	Cumulative operating time of the inverter (h)	0~9999h	1h	
U0.16	Power-on accumulation time of the inverter (h)	0~9999h	1h	
U0.17	U-phase current sample bias value	0~4095		
U0.18	V-phase current sample bias value	0~4095		
U0.19	W-phase current sample bias value	0~4095		

Fault codes			
Code	Name	Possible causes of failure	Failure countermeasures
OU1 (1)	Overvoltage in acceleration	Input voltage is abnormal	Check the input power supply
		Restart the rotating motor	Set to start after DC braking
OU2 (2)	Overvoltage in deceleration	Deceleration time too short	Extended deceleration time
		Input voltage is abnormal	Check the input power supply
OU3 (3)	Overvoltage in constant speed	Input voltage is abnormal	Check the input power supply
OCC1 (4)	Hardware-accelerated overcurrent	Acceleration time too short	Extend acceleration time
		Inverter power is too small	Choose Inverter with a large power level
		Improper setting of the V/F	Adjust the V/F curve or torque lift

		curve or torque lift	
		IGBT module is damaged	Contact the supplier for service
OCC2 (5)	Hardware-deceleration overcurrent	Deceleration time too short	Extended deceleration time
		Inverter power is too small	Choose Inverter with a large power level
		IGBT module is damaged	Contact the supplier for service
OCC3 (6)	Hardware constant speed overcurrent	The grid voltage is low	Check the input power supply
		Load is abrupt or abnormal	Check the load or reduce the load mutation
		Inverter power is too small	Choose Inverter with a large power level
OCS1 (7)	Software-accelerated overcurrent	IGBT module is damaged	Contact the supplier for service
		Acceleration time too short	Extend acceleration time
		Inverter power is too small	Choose Inverter with a large power level
OCS2 (8)	Software-deceleration overcurrent	Improper setting of the V/F curve or torque lift	Adjust the V/F curve or torque lift
		Deceleration time too short	Extended deceleration time
		Inverter power is too small	Choose Inverter with a large power level
OCS3 (9)	Software-constant speed overcurrent	The grid voltage is low	Check the input power supply
		Load is abrupt or abnormal	Check the load or reduce the load mutation
		Inverter power is too small	Choose Inverter with a large power level
EFO (10)	The power module is faulty	Inverter output is short-circuited or grounded	Check the motor wiring
		Inverter is overcurrent instantaneously	See Overcurrent Countermeasures
		Control board is abnormal or interferes severely	Contact the supplier for service
		Power device is damaged	Contact the supplier for service
OU (11)	Overvoltage during shutdown	Input voltage is abnormal	Check the input power supply
OU3 (12)	Overvoltage in constant speed	Power supply voltage is too high	Check the input power supply
		Load is abrupt or abnormal	Check the load or reduce the load mutation
LU (13)	Undervoltage	Input voltage is abnormal	Check the input power supply
		Relay is not engaged	Contact the supplier for service
OH (14)	Overtemperature	Ambient temperature is too high	Improving the environment
		There is little space around the inverter	Adjust the space
		Blocked air ducts	Clean and drain the ventilation ducts
		Cooling fan is not running	Check the power supply of the fan and the fan itself
OL2 (15)	Inverter overload	Improper setting of the V/F curve or torque lift	Adjust the V/F curve or torque lift
		The grid voltage is low	Check the input power supply
		Acceleration time too short	Extend acceleration time
		Motor is overloaded	Choose Inverter with a large power level
OL1 (16)	Motor overload	Improper setting of the V/F curve or torque lift	Adjust the V/F curve or torque lift
		The grid voltage is low	Check the input power supply
		Motor stalls or the load abrupt change is too large	Check the load
		The motor overload protection factor is set incorrectly	Set the motor overload protection factor correctly
BIAS (17)	Current bias is wrong	Hardware failure	Contact the supplier for service
CBC (18)	Wave-by-wave current limiting faults	Inverter power is too small	Choose Inverter with a large power level
		Load is abrupt or abnormal	Check the load or reduce the load mutation
FBL (19)	PID feedback low lower limit	The PID feedback line is loose	Check the feedback link
		The feedback amount is less than the disconnection detection value	Adjust the detection input threshold
FBH (20)	PID feedback over upper limit	When the PID feedback amount is greater than the feedback excess detection value, and the duration exceeds the PID feedback excess detection time, the inverter alarms the fault FBH	Check the feedback link
			Adjust the detection input threshold
EEEEP (21)	EEPROM read and write errors	EEPROM failure	Contact the supplier for service
CE (22)	Dual CPUs Communication failures	CPU failure	Contact the supplier for service
EF (23)	Failure of external devices	The external device fault input terminal is closed	Disconnect the faulty input terminal of the external device and clear the fault (pay attention to check the cause)
EPA (24)	Faulty parameter settings		
OLP (26)	Parameter identification output, phase loss	Refer to fault code 29	Check whether the communication line connection is abnormal and whether the line sequence is correct.
SFOC (27)	Software overcurrent		Adjust acceleration and deceleration time; If the motor parameters do not match, the parameters will be re-identified;

SPO (29)	Output loss phase	The wiring from the inverter to the motor is abnormal	Troubleshoot wiring
		The 3-phase output of the inverter is unbalanced	Check whether the three-phase winding of the motor is normal
		The driver board is abnormal	Seek service from the manufacturer
		The module is abnormal	Seek service from the manufacturer
OL3 (33)	Inverter overload warning failure	The drive is about to be overloaded	
AUTH (34)	Unauthorized	Not out of the factory authorization process.	Return to the factory.
LCP (35)	Input loss phase	The input voltage is out of phase	Check the input circuitry.
Warning codes			
EPA1	parameter settings are incorrect	3-wire function of the inverter is not set correctly	Check whether the 3-wire system of the inverter terminal is set correctly
SLEP	Sleep Mode	inverter goes into sleep mode	

精巧型变频器 YD180 系列 用户说明书

200V 级 0.4 – 2.2kW

400V 级 0.75 – 2.2kW

- 请仔细阅读说明书，理解各项内容，以便正确安装使用
- 请将说明书交给最终客户，并妥善保存
- 本产品技术规格可能发生变化，恕不另行通知



版本 V1.0

郑重声明

感谢使用变频器，在使用前，一定要认真阅读本使用说明书，请在熟知本产品安全注意事项后使用。

安全注意事项：

- 1、接线前，请确认输入电源是否处于断电状态。
- 2、接线作业，请专业电气工程人员进行。
- 3、接地端子，请一定要接地。
- 4、紧急停止回路接线完成后，请一定要检查动作是否有效。
- 5、变频器的输出线切勿与外壳连接，输出线切勿短路。
- 6、请确认交流主回路电源的电压与变频器的额定电压是否一致。
- 7、请勿对变频器进行耐电压试验。
- 8、请按接线图连接制动电阻。
- 9、请勿将电源线接到输出 U、V、W 端子上。
- 10、请勿将接触器接入输出回路。
- 11、通电前务必安装好保护罩。拆卸外罩时，请一定要断开电源。
- 12、选择复位再试功能的变频器，请勿靠近机械设备。因为报警停止时会突然再起动。
- 13、确认运行信号被切断后，方可报警复位。运行信号状态下进行报警复位，变频器有可能会突然起动。
- 14、变频器的端子切勿触摸，端子上有高电压，非常危险。
- 15、通电中，请勿变更接线及端子拆装。
- 16、切断主回路电源，才可以进行检查、保养。
- 17、请勿擅自改造变频器。

型号命名

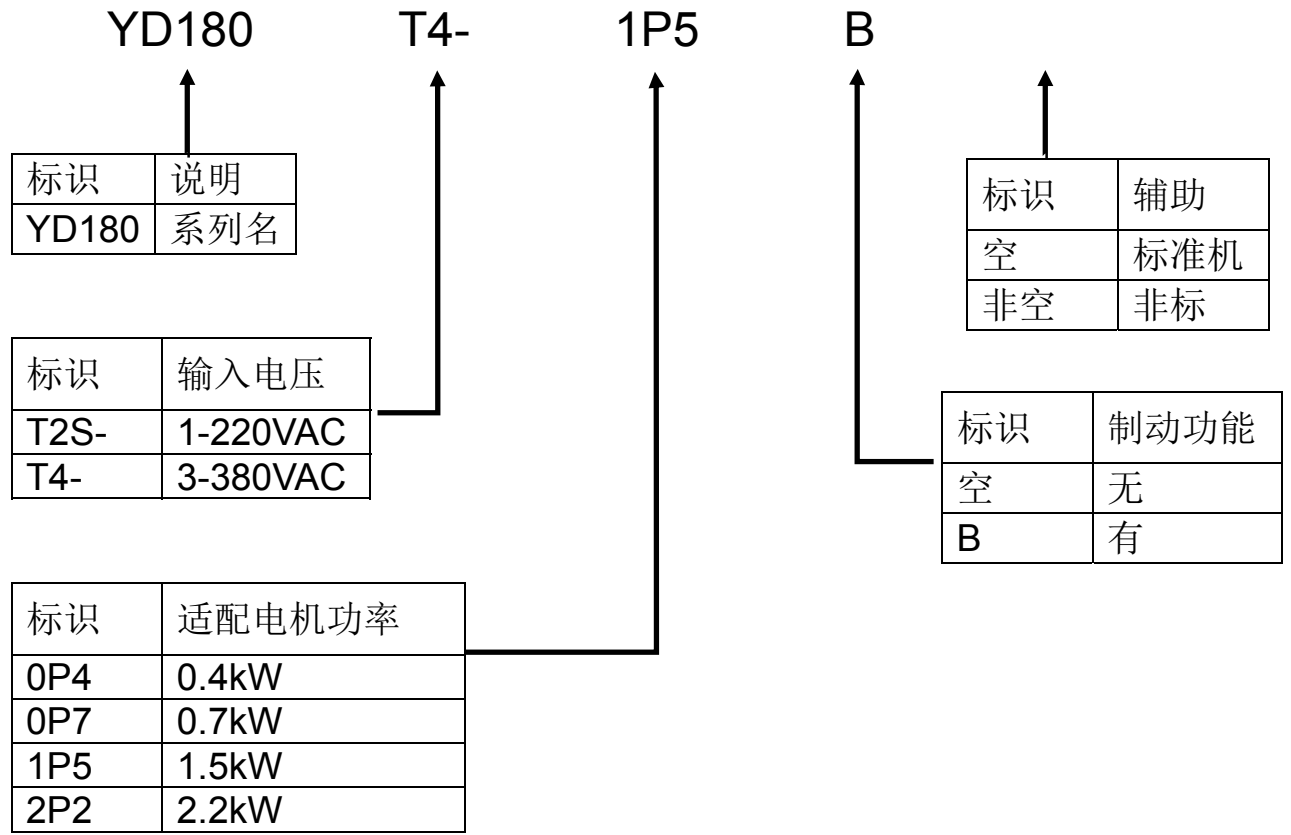

电气规格

变频器额定数据					
机种型号	功率	输入电压 (AC)	输出电流 (A)	外形尺寸 HxWxD (mm)	安装尺寸 HxW-螺钉 (mm)
YD180T2S-0P4B	0.4kW	单相 200-240V	2.1	172.3x79x128.5	158x60-M5
YD180T2S-0P7B	0.75kW		3.8		
YD180T2S-1P5B	1.5kW		7.0		
YD180T2S-2P2B	2.2kW		9.0	190.5x86x145	170x68-M4
YD180T4-0P7B	0.75kW	三相 340-440V	2.1	172.3x79x128.5	158x60-M5
YD180T4-1P5B	1.5kW		3.8		
YD180T4-2P2B	2.2kW		5.1	190.5x86x145	170x68-M4

制动电阻规格

机种型号	功率	输入电压 (AC)	电阻功率 10% (W)	电阻阻值 (Ω)
YD180T2S-0P4B	0.4kW	单相 200-240V	100	250
YD180T2S-0P7B	0.75kW		100	200
YD180T2S-1P5B	1.5kW		300	100
YD180T2S-2P2B	2.2kW		300	100
YD180T4-0P7B	0.75kW	三相 340-440V	100	750
YD180T4-1P5B	1.5kW		300	400
YD1804-2P2B	2.2kW		300	250

面板托尺寸

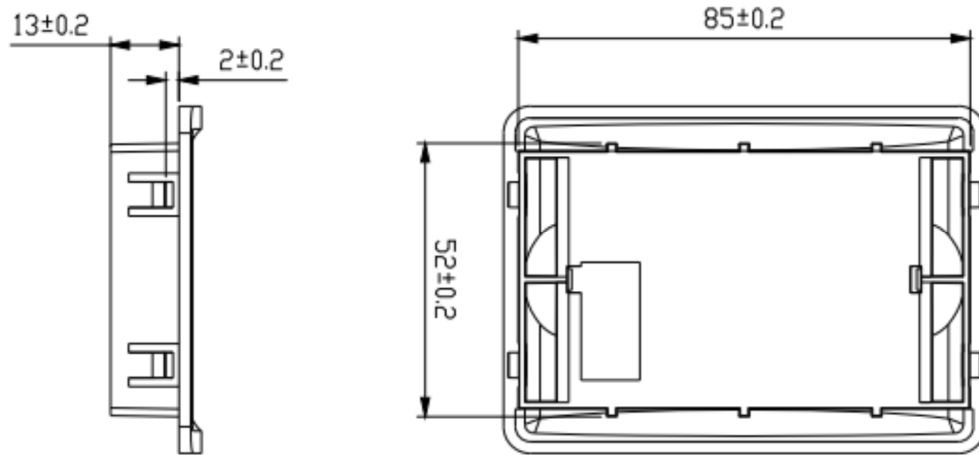

安装与接线

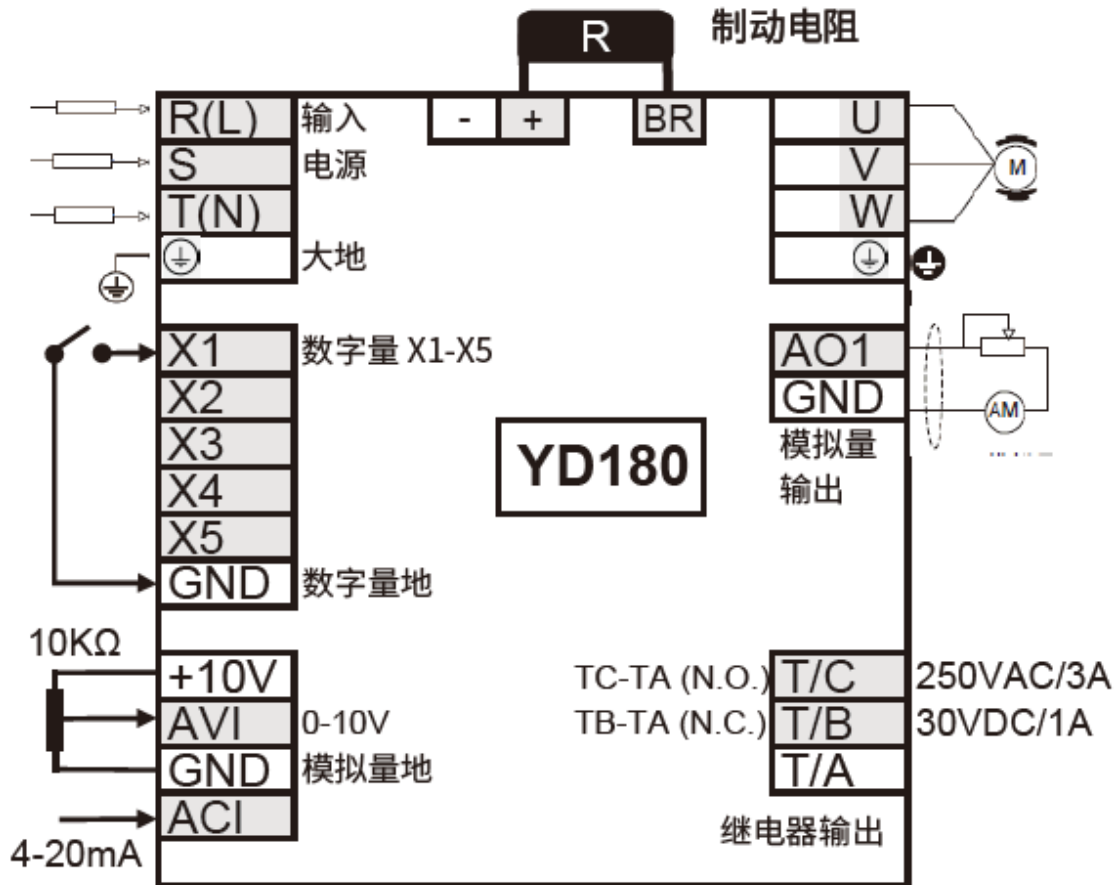

端子名称	用途	设定及说明
R、S、T (L、N)	变频器电源： 380V 机型接 R、S、T 220V 机型接 L、N	变频器输入电源前端应使用空气开关作为过流保护装置，若加有漏电保护开关，为防止漏电开关误动作，请选择感度 200mA 以上，动作时间 100ms 以上的设备。
U、V、W	变频器输出，连接电机	为减小漏电流，电机连接线尽量不要超过 50 米。
≡	接地	变频器要良好接地。
+，BR	制动专用端子	接合适的制动电阻
X1	数字输入 X1	通过参数 P5.02 设定，出厂默认为正转
X2	数字输入 X2	通过参数 P5.03 设定，出厂默认为反转
X3	数字输入 X3	通过参数 P5.04 设定，出厂默认为多段速第一位
X4	数字输入 X4	通过参数 P5.05 设定，出厂默认为多段速第二位
X5	数字输入 X5	通过参数 P5.06 设定，出厂默认为外部复位信号输入
GND	信号公共端	输入输出信号的零电位
AVI	0-10V 信号输入	0-10V
+10V	频率设定电位器电源	+10V，最大 10mA
ACI	4-20mA 模拟量输入	0-20mA 或 4-20mA
AO1	模拟量输出信号	通过参数 P6.10 设定
TA、TB、TC	继电器输出	通过参数 P5.07 设定 触点容量：AC 250V/3A DC 24V/2A

调试与运行

① 操作面板及操作方法

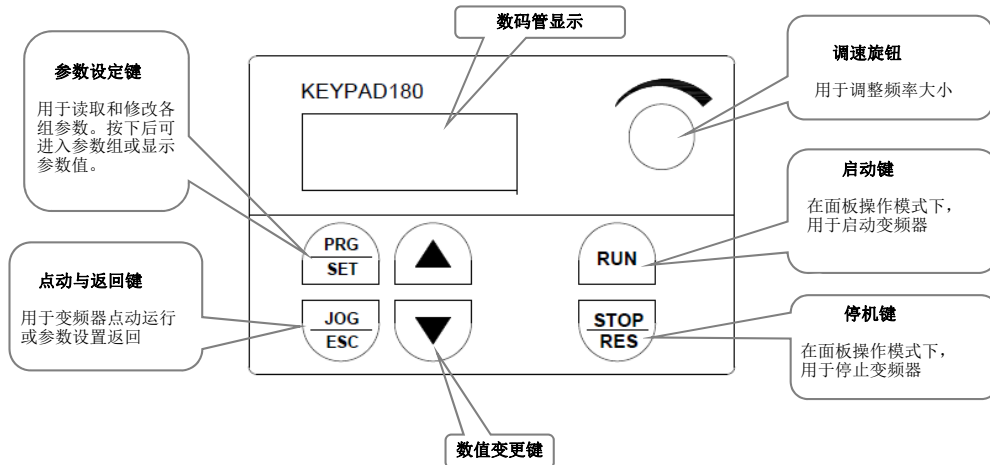

按键	名称	功能说明
PRG/SET	编程键 设定键	在零级菜单(运行界面), 一级菜单、二级菜单情况下, 按此键进入下一级菜单。 在三级菜单的情况下, 按此键为设定参数的设定。
JOG/ESC	多功能键(默认点动) 返回键	在零级菜单(运行界面), 按此键可根据 P4.06 设定的功能切换选择。 在一级菜单、二级菜单、三级菜单的情况下, 此键为返回前一级菜单。
▲	递增键	功能码、菜单组、或设定参数值递增。
▼	递减键	功能码、菜单组、或设定参数值递减。
RUN	运行键 移位键	在零级菜单(运行界面)的情况下, 用于启动变频器。 在二级、三级菜单的情况下, 可以改变欲设置数据的修改位。
STOP/RES	停止键 复位键	运行状态时用于停机操作键。 故障报警状态时用于复位操作键。

参数 P 设定前的密码解除(流程 0)

P 群参数修改或设定前，在每次进入第一级菜单前，得做密码解除的动作，若回到零级得在重设：

- 1、上电后，在-P0-界面的下一级显示“0000”，输入密码才能进入下一级菜单。
- 2、如果之前没有设定密码，直接按数值为“0001”后，才可进行参数修改。

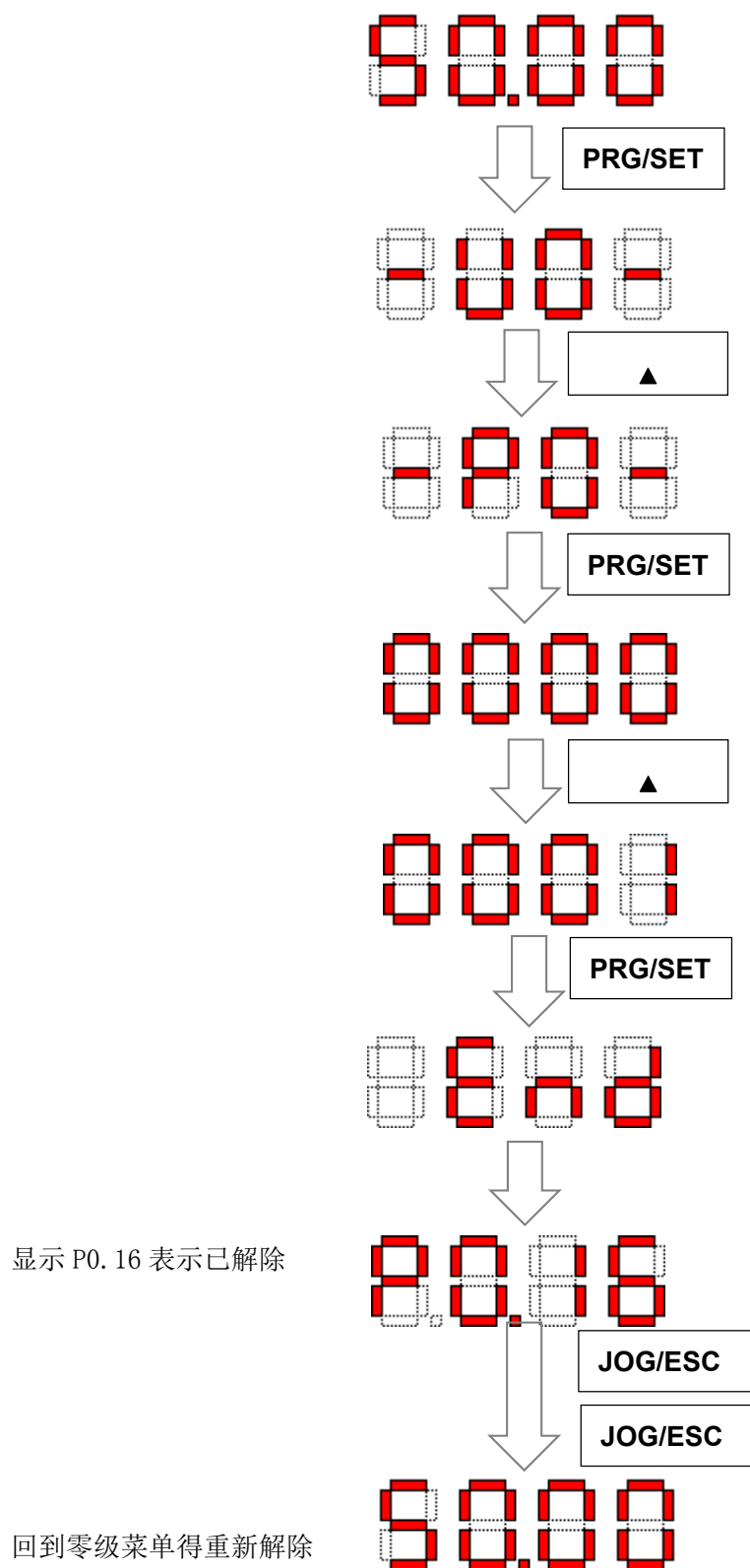

监控参数(流程 1)

- 1、进入一级参数-U0-
- 2、进入二级参数 U0.04,
- 3、进入三级看电流输出数据,
- 4、最后返回零级界面:

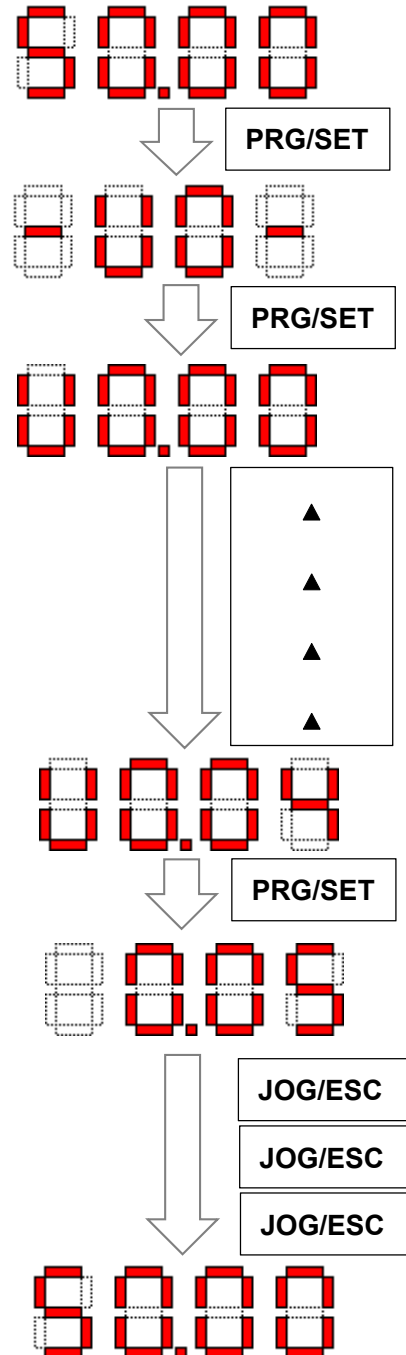

表示 0.05A

调试参数(流程 2)

- 0、先解除密码(参考流程 0)
- 1、进入一级参数-P1-
- 2、进入二级参数 P1.03.
- 3、进入三级修改载波频率为 2Khz.
- 4、最后返回零级界面:

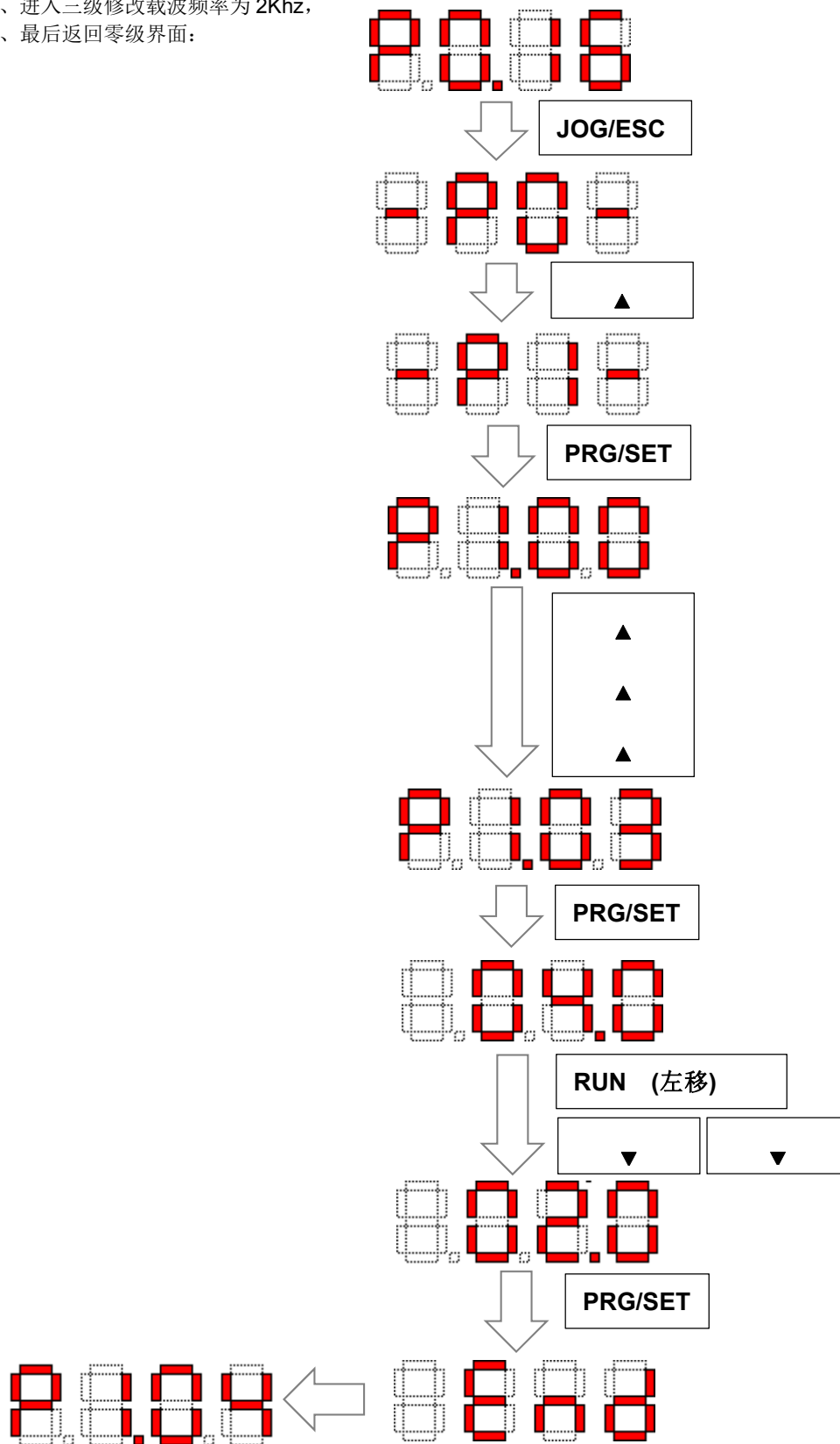

4、参数表

参数	名称	出厂值	设定范围	说明	
P0 组-基本运行参数					
P0.00	变频器功率	按机型	0.4-2.2kw	变频器当前功率。	
P0.01	控制方式	0	0-1	0: V/F 控制 1: 开环矢量	
P0.02	运行命令选择	1	0-1	0: 面板运行命令 1: 端子运行命令	
P0.03	主频率源 X 选择	5	0-7	0: 数字设定 (预置频率 P0-07, UP/DOWN, 根据 P0.07 的值修改可修改, 掉电不记忆) 1: 数字设定 (预置频率 P0-07, UP/DOWN, 根据 P0.07 的值修改可修改, 掉电记忆) 2: (AVI) 3: (ACI) 4: (键盘电位器) 5: 多段速指令 6: 简易 PLC 7: PID	
P0.04	辅助频率源 Y 选择	0	0-7	同 P0.03	
P0.05	主辅频运算	0	0-3	0: 主+ 辅 1: 主- 辅 2: 二者最大值 3: 二者最小值	
P0.06	频率源选择	0	0-4	0: 主频率源 X (P0.03) 1: 主辅运算结果 (P0.05) 2: 主频率源 X (P0.03) 与辅助频率源 Y (P0.04) 切换 3: 主频率源 X (P0.03) 与主辅运算结果 (P0.05) 切换 4: 辅助频率源 Y (P0.04) 与主辅运算结果 (P0.05) 切换 注: 切换由端子(X1-X5), 设定 18	
P0.07	频率数字设定	12.50Hz	0-最大频率	该设定值是频率数字给定初始值	
P0.08	最大输出频率	50.00Hz	上限频率-400.0Hz	最大输出频率是变频器允许输出的最高频率, 是加减速设定的基准。	
P0.09	上限频率	50.00Hz	下限频率-最大输出频率	运行频率不能超过该频率	
P0.10	下限频率	0.00Hz	0-上限频率	运行频率不能低于该频率。	
P0.11	下限频率到达处理	0	0-2	0: 零速运行 1: 以下限频率运行 2: 停机	
P0.12	第一加速时间	5.0s	0.1~6500.0s	变频器从零频加速到最大输出频率所需时间	
P0.13	第一减速时间	2.2s	0.1~6500.0s	变频器从最大输出频率减速到零频所需时间	
P0.14	运行方向	0	0-2	0: 正转, 1: 反转, 2: 禁止反转 本参数正、反转选择为运行命令来源于面板时有效。 禁止反转则不论运行命令来源为哪种方式, 变频器都不反转。	
P0.15	用户密码	0	0~9999	设置密码, 在“-P0-”界面的下一级显示“0000”, 需要输入密码才能进入下一级菜单; 设置一个非零的数字时密码生效; 解密后设置 0000, 则密码功能取消。	
P0.16	软件版本	xx.xx	01.00-99.99	当前软件版本。	
P0.17	参数初始化	0	0-3	0: 无操作 1: 恢复出厂值 (不包括电机参数) 2: 故障清除 3: 所有参数恢复出厂值 (包括电机参数)	
P0.18	保留				
P0.19	频率小数点	2	1~2	1: 0.1Hz (频率最高可设置 4000Hz) 2: 0.01Hz (频率最高可设置 400.0Hz)	
P0.20	数字设定 停机保持	1	0~1	0: 不保持 1: 保持	
P1 组-V/F 控制参数					
P1.00	V/F 曲线设定	0	0-6	0: 线性曲线 1: 平方曲线 2: 1.5 次方曲线 3: 1.2 次方曲线 4: 多点 V/F 曲线 5: V/F 完全分离 6: V/F 半分离	
P1.01	转矩提升量	按机型	0.0~30.0%	手动转矩提升量, 此值设定是相对于电机额定电压的百分比。 为 0 时, 切换到自动转矩提升。	
P1.02	转矩提升截止频率	50.00Hz	0.0~50.00Hz	该手动转矩提升时的提升截止频率点	
P1.03	载波频率设置	按机型	2.0~16.0KHz	提高载波频率可以降低噪音, 但提高载波频率会使变频器的发热量增加。	
P1.04	V/F 频率值 P1	12.50Hz	0.01~频率值 P2	<p>The graph shows a V/F curve with voltage on the y-axis and frequency on the x-axis. The y-axis has points V1, V2, V3, and 电机额定电压. The x-axis has points F1, F2, F3, and 最大输出频率. The curve starts at the origin, passes through (F1, V1), (F2, V2), and (F3, V3), and ends at (最大输出频率, 电机额定电压). The curve is piecewise linear, with a steeper slope between F2 and F3.</p>	
P1.05	V/F 电压值 V1	25.0%	0.0~电压值 V2		
P1.06	V/F 频率值 P2	25.00Hz	频率值 P1~频率值 P3		
P1.07	V/F 电压值 V2	50.0%	电压值 V1~电压值 V3		
P1.08	V/F 频率值 P3	37.50Hz	频率值 P2~电机额定频率		
P1.09	V/F 电压值 V3	75.0%	电压值 V2~100.0%(电机额定电压)		
P1.10	转矩提升模式	7	0~7		
P1.11	制动率	90%	0~100%		制动电阻制动率

参数	名称	出厂值	设定范围	说明
P1.12	转矩补偿增益	100%	0~300%	
P1.13	V/F 过励磁增益	按机型	0~200%	
P1.14	振荡抑制模式	3	0~4	V/F 模式下, 对于大多数的电机, 低频时会出现速度振荡与电流振荡的现象, 振荡可能会导致变频器过流。使能振荡抑制, 可以消除振荡。 0: 无效 1: 保留 2: 保留 3: 有效 4: 保留
P1.15	V/F 分离的电压源	0	0~9	0: 数字给定(P1.16) 1: AVI 2: ACI 3: 键盘电位器 4: 保留 5: 多段速 6: PLC 7: PID 8: 保留 9: 电流闭环
P1.16	V/F 分离的电压源数字设定	0	0~ 电机额定电压	
P1.17	V/F 分离的电压上升时间	0.0	0.0~1000.0	
P1.18	V/F 分离的电压减速时间	0.0	0.0~1000.0	
P1.19	V/F 分离停机方式选择	0	0~1	0: 根据 P3.05 方式停机 1: 电压减为 0 后频率再减
P1.20	V/F 分离电流闭环控制设定值	100	0~ 电流限幅水平	
P2 组-矢量控制参数				
P2.00	速度环低速 Kp	20	1~100	
P2.01	速度环低速 Ki	0.50	1~10.00	
P2.02	速度环高速 Kp	10	1~100	
P2.03	速度环高速 Ki	1.00	1~10.00	
P2.04	速度环低速频率计算切换点	10.00Hz	下限频率~ 最大频率	
P2.05	速度环高速频率计算切换点	30.00Hz	下限频率~ 最大频率	
P2.06	电动转差补偿增益	0%	0~200.0%	
P2.07	保留			
P2.08	保留			
P2.09	保留			
P2.10	电流环 Kp	2000	0~6000	
P2.11	电流环 Ki	1300	0~6000	
P2.12	保留			
P2.13	保留			
P2.14	开环矢量转差补偿增益	100%	0~200%	
P2.15	保留			
P2.16	保留			
P2.17	保留			
P2.18	保留			
P2.19	速度控制(驱动)转矩上限数字设定	150.0%	0~200.0%	
P2.20	弱磁区最大转矩系数	100%	50~200%	
P2.21	M 轴电流环比例系数	5	5~300	
P2.22	M 轴电流环积分系数	0	0~6553	
P2.23	开环矢量速度环滤波时间常数	0.25	0~1.00	
P2.24	开环矢量转矩提升	100	0~500	
P2.25	开环矢量转矩提升截止频率	20.00Hz	下限频率~ 最大频率	
P2.26	转矩给定滤波	28	0~31	
P2.27	最大弱磁电压过调制系数	105%	0~120%	
P2.28	磁通观测补偿系数	100%	0~200%	
P2.29	磁通观测滤波系数	300	0~2000	
P2.30	T 轴电流闭环	0	0~500	

参数	名称	出厂值	设定范围	说明
	系数			
P2.31	转矩限幅方式	1	0~1	
P3组-辅助运行参数				
P3.00	启动方式	0	0-1	0: 由启动频率启动 1: 直流制动后由启动频率启动
P3.01	启动频率	0.50Hz	0.50~20.00Hz	变频器启动的初始频率
P3.02	启动频率保持时间	0	0.0~60.0s	启动频率运行时间
P3.03	启动直流制动电流	0.0%	0.0~100%	施加直流制动的电流值 当电机额定电流小于或等于变频器额定电流的 80% 时, 是相对电机额定电流为百分比基值; 当电机额定电流大于变频器额定电流的 80% 时, 是相对 80% 的变频器额定电流为百分比基值。
P3.04	启动直流制动时间	0.0s	0.0~60.0s	施加直流制动持续的时间
P3.05	停机方式	1	0~2	0: 减速停机, 1: 减速停机 + 直流制动 2: 自由停机
P3.06	停机直流制动起始频率	12.40Hz	0.00~上限频率	频率到达预设定的频率开始直流制动
P3.07	停机直流制动电流	20.0%	0.0~100%	施加直流制动的电流值,同启动直流制动
P3.08	停机直流制动时间	1.0s	0.0~30.0s	施加直流制动持续的时间
P3.09 ~ P3.15	保留			
P3.16	STOP/RESET 键功能	1	0-1	0: 无状态 1: 任何情况都启用
P4组-辅助运行参数 2				
P4.00	正转点动频率设定	10.00Hz	0.00~50.00Hz	设定点动正反转频率
P4.01	反转点动频率设定			
P4.02	点动加速时间	按机型	0.1~999.9s	设定点动加减速时间
P4.03	点动减速时间			
P4.04	第二加速时间	10.0s	0.1~999.9s	
P4.05	第二减速时间	10.0s	0.1~999.9s	
P4.06	多功能按键	1	0~3	0: 点动运行; 1: 点动运行, 优先级最高 2: 当前电机方向反转运行; 3: 正反转切换;
P4.07	跳跃频率	0.00Hz	0.0~上限频率	通过设置跳跃频率及范围, 可以使变频器避开负载的机械共振点。
P4.08	跳跃范围	0.00Hz	0.0~10.0Hz	
P4.09	跳跃频率 2	0.00Hz	0.0~上限频率	
P4.10	跳跃范围 2	0.00Hz	0.0~10.0Hz	
P4.11	跳跃频率 3	0.00Hz	0.0~上限频率	
P4.12	跳跃范围 3	0.00Hz	0.0~10.0Hz	
P4.13	跳跃频率 4	0.00Hz	0.0~上限频率	
P4.14	跳跃范围 4	0.00Hz	0.0~10.0Hz	
P5组-数字输入输出参数				
P5.00	FWD/REV 端子控制模式	0	0-3	0: 二线式控制模式 1 1: 二线式控制模式 2 2: 三线式控制模式 1 3: 三线式控制模式 2
P5.01	上电时端子功能检测	0	0-1	0: 上电时端子运行命令无效 1: 上电时端子运行命令有效
P5.02	输入端子 X1 功能	3	0~30	0: 无功能 1: 正转点动控制
P5.03	输入端子 X2 功能	4	0~30	2: 反转点动控制 3: 正转控制 (FWD) 4: 反转控制 (REV)
P5.04	输入端子 X3 功能	12	0~30	5: 三线式运转控制 6: 自由停机控制
P5.05	输入端子 X4 功能	13	0~30	7: 外部停机信号输入(STOP) 8: 外部复位信号输入(RST) 9: 外部故障常开输入
P5.06	输入端子 X5 功能	8	0~30	10: 频率递增指令 (UP) 11: 频率递减指令 (DOWN) 12: 多段速选择 S1 13: 多段速选择 S2 14: 多段速选择 S3 15: 运行命令通道强制为端子 16: 保留 17: 停机直流制动指令 18: 频率源切换(P0.06) 19-21: 保留 22: 计数器清零信号(Pb.10 计数功能) 23: 计数器触发信号(Pb.10 计数功能) 24: 定时器清零信号(Pb.10 定时功能) 25: 定时器触发信号(Pb.10 定时功能) 26: 加减速时间选择(加减速时间一与加减速时间二切换选择) 27-28: 保留 29: 停机控制 (需要重新给运行命令) 30: 正反转切换

参数	名称	出厂值	设定范围	说明
P5.07	继电器 R 输出功能设定	5	0~14	0: 无功能 1: 变频器运行准备就绪 2: 变频器运行中 3: 变频器零速运行中 4: 外部故障停机 5: 变频器故障 6: 频率/速度到达信号 (FAR) 7: 频率/速度水平检测信号 (FDT) 8: 输出频率到达上限 9: 输出频率到达下限 10: 变频器过载预报警 11: 定时器溢出信号(当定时时间达到 Pb.13 的定时设定时间时继电器输出) 12: 计数器检测信号(当计数值达到 Pb.12 的计数器检出值时继电器输出) 13: 计数器复位信号(保留) 14: 保留
P5.08	R 闭合延时	0.0s	0.0~999.9s	继电器 R 状态发生改变到输出产生变化的延时
P5.09	R 断开延时			
P5.10	频率到达 FAR 检测幅度	5.00Hz	0.00Hz~15.00Hz	输出频率在设定频率的正负检出宽度内, 端子输出有效信号(低电平)。
P5.11	FDT 水平设定值	10.00Hz	0.00Hz~上限频率	
P5.12	FDT 滞后值	1.00Hz	0.00~30.00Hz	
P5.13	UP/DOWN 端子修改速率	1.00Hz/s	0.10Hz~200.00Hz/s	设置 UP/DOWN 端子设定频率时的频率修改速率, 即 UP/DOWN 端子与 COM 端短接一秒钟, 频率改变量的大小。
P5.14	保留			
P5.15	输入端子有效逻辑设定 (X1~X5)	0	0~31	Bit0 ~ Bit4 分别对应 X1 ~ X5 0: 表示正逻辑, 即 Xi 端子与公共端连通有效, 断开无效 1: 表示反逻辑, 即 Xi 端子与公共端连通无效, 断开有效
P5.16	X1 滤波系数	5	0~9999	用于设置输入端子的灵敏度。若数字输入端子易受到干扰而引起误动作, 可将此参数增大, 则抗干扰能力增强, 但设置过大将导致输入端子的灵敏度降低。1: 代表 2MS 扫描时间单位
P5.17	X2 滤波系数	5	0~9999	
P5.18	X3 滤波系数	5	0~9999	
P5.19	X4 滤波系数	5	0~9999	
P5.20	X5 滤波系数	5	0~9999	
P6 组-模拟量输入输出功能				
P6.00	AVI 输入下限电压	0%	0.0~120.0%	设置 AVI 下限电压
P6.01	AVI 输入上限电压	100.0%	0.0~120.0%	设置 AVI 上限电压
P6.02	AVI 下限对应设定	0.0%	-100.0%~120.0%	设置 AVI 下限对应设定, 该设定对应最大频率的百分比。
P6.03	AVI 上限对应设定	100.0%	-100.0%~120.0%	设置 AVI 上限对应设定, 该设定对应最大频率的百分比。
P6.04	ACI 输入下限电流	0.0%	0.0~120.0%	设置 ACI 输入下限电流 ▲ 0-20mA(P6-04=0.00%) / 4-20mA(P6-04=20.0%)
P6.05	ACI 输入上限电流	100.0%	0.0~120.0%	设置 ACI 输入上限电流
P6.06	ACI 下限对应设定	0.0%	-100.0%~120.0%	设置 ACI 下限对应设定, 该设定对应最大频率的百分比。
P6.07	ACI 上限对应设定	100.0%	-100.0%~120.0%	设置 ACI 上限对应设定, 该设定对应最大频率的百分比。
P6.08	模拟输入信号滤波时间常数	0.1s	0.1~5.0s	此参数用于对 AVI、ACI 和面板电位器输入信号的滤波处理, 以消除干扰的影响。
P6.09	模拟输入防抖偏差极限	0	0.00~100.0%	当模拟输入信号在给定值附近出现频繁波动时, 可以通过设置此参数来抑制此波动导致的频率波动。
P6.10	AO1 模拟量输出端子功能选择	0	0~5	0: 输出频率, 0~最大频率 1: 设定频率, 0~最大频率 2: 输出电流, 0~2 倍额定电流 3: 输出电压, 0~2 倍额定电压 4: AVI, 0~10V 5: ACI, 0~20mA
P6.11	AO1 功能下限	0.0	0.0~120.0%	设置 AO1 选择的功能上下限
P6.12	AO1 功能上限	100.0%		
P6.13	AO1 输出下限	0.0		
P6.14	AO1 输出上限	100.0%		
P6.15	面板电位器输入下限电压	10.9%	0.0~120.0%	设置面板电位器下限电压
P6.16	面板电位器输入上限电压	96.0%	0.0~100.0%	设置面板电位器上限电压
P6.17	面板电位器下限对应设定	0.0%	-100.0%~120.0%	设置面板电位器下限对应设定, 该设定对应最大频率的百分比。
P6.18	面板电位器上限对应设定	100.0%	-100.0%~100.0%	设置面板电位器上限对应设定, 该设定对应最大频率的百分比。
P6.19	面板电位器防抖偏差极限	3.5%	0.00~100.0%	当面板电位器在给定值附近出现频繁波动时, 可以通过设置此参数来抑制此波动导致的频率波动。
P6.20	面板电位器滤波时间常数	0.1s	0.1~5.0s	此参数用于对面板电位器输入信号的滤波处理, 以消除干扰的影响。
P7 组-程序运行参数(PLC)				
P7.00	多段速频率 1	5.00Hz	下限频率~上限频率	设置段速 1 频率
P7.01	多段速频率 2	10.00Hz	下限频率~上限频率	设置段速 2 频率
P7.02	多段速频率 3	15.00Hz	下限频率~上限频率	设置段速 3 频率
P7.03	多段速频率 4	20.00Hz	下限频率~上限频率	设置段速 4 频率
P7.04	多段速频率 5	25.00Hz	下限频率~上限频率	设置段速 5 频率

参数	名称	出厂值	设定范围	说明
P7.05	多段速频率 6	37.50Hz	下限频率~ 上限频率	设置段速 6 频率
P7.06	多段速频率 7	50.00Hz	下限频率~ 上限频率	设置段速 7 频率
P7.07	可编程运行控制 (简易 PLC 运行)	0	0~2	0: 单循环 1: 连续循环 2: 单循环后保持最终值
P7.08	停机记忆选择	0	0~1	0: 停机不记忆 1: 停机记忆
P7.09	掉电记忆选择	0	0~1	0: 掉电不记忆 1: 掉电记忆
P7.10	T1 运行时间	10.0s	0.0~999.9s	设置段速 1 运行时间
P7.11	T2 运行时间	10.0s	0.0~999.9s	设置段速 2 运行时间
P7.12	T3 运行时间	10.0s	0.0~999.9s	设置段速 3 运行时间
P7.13	T4 运行时间	10.0s	0.0~999.9s	设置段速 4 运行时间
P7.14	T5 运行时间	10.0s	0.0~999.9s	设置段速 5 运行时间
P7.15	T6 运行时间	10.0s	0.0~999.9s	设置段速 6 运行时间
P7.16	T7 运行时间	10.0s	0.0~999.9s	设置段速 7 运行时间
P7.17	T1 运行模式	0	0~3	0: 正转, 选择加速时间 1 1: 正转, 选择加速时间 2 2: 反转, 选择加速时间 1 3: 反转, 选择加速时间 2
P7.18	T2 运行模式	0		
P7.19	T3 运行模式	0		
P7.20	T4 运行模式	0		
P7.21	T5 运行模式	0		
P7.22	T6 运行模式	0		
P7.23	T7 运行模式	0		
P7.24	当前运行段 (保留)			
P7.25	当前运行时间 (保留)			
P7.26	多段速优先	1	0~1	0: 不优先 1: 多段速优先, 优先级低于点动
P8 组-PID 参数				
P8.00	PID 控制特性	0	0~1	0: 正作用 1: 反作用
P8.01	PID 给定量选择	0	0~3	0: 数字设定 1: 键盘电位器设定 2: AVI 输入 3: ACI 输入
P8.02	PID 反馈量选择	0	0~1	0: AVI 输入 1: ACI 输入
P8.03	PID 数字设定	3.0	PID 量程下限~ PID 量程上限	当 PID 给定源为数字设定时的给定值
P8.04	PID 指令加减速时间	0.0	0.00~100.0s	
P8.05	PID 偏置设定	0.0	0 ~100.0%	
P8.06	PID 偏置保持时间	0.0	0 ~6000.0s	
P8.07	PID 偏差上限	100.0	0 ~100.0%	
P8.08	PID 偏差下限	0.0	00.0%~ 100.0% (最大频率)	
P8.09	比例增益	5.00	0.00~600.00	
P8.10	积分时间	2.0	0:无积分 0.1~100.0s	
P8.11	微分时间	0.00	0.00:无微分 0.00~10.00s	
P8.12	PID 输出上限	100.0	0.0~100.0%	
P8.13	PID 输出下限	0.0	0.0~100.0%	
P8.14	PID 输出滤波时间	0.00	0.00~10.00s	
P8.15	反馈故障动作选择	2	0~4	0: 按上限频率运行 1: 按下限频率运行 2: 按数字设定频率运行 3: 减速停车 4: 自由停车
P8.16	丧失检出值	0.0	0.0~100.0%	
P8.17	丧失检出时间	1.0	0.0~100.0s	
P8.18	超值检出值	100.0	0.0~100.0%	
P8.19	超值检出时间	1.0	0.0~100.0s	
P8.20	PID 睡眠控制	0	0~2	0:无睡眠功能 1:内部唤醒 2:外部输入端子控制
P8.21	休眠停机模式	0	0~1	0: 减速停机 1: 自由停机
P8.22	睡眠频率	0.00	0.00 Hz ~ 最大频率	
P8.23	睡眠压力	95.0%	P8.25 ~100.0%	
P8.24	睡眠延时时间	30.0	0.0~6000.0s	
P8.25	唤醒压力	80.0%	0.0%~P8.23	
P8.26	唤醒延时时间	3.0	0.0~60.0s	
P8.27	PID 量程下限	0.0	-3276.8~ 3276.8	由于显示屏为 4 个数码管, 所以显示的位数可能与实际值不符, 但是不影响最终设定的值。
P8.28	PID 量程上限	10.0	-3276.8~ 3276.8	由于显示屏为 4 个数码管, 所以显示的位数可能与实际值不符, 但是不影响最终设定的值。

参数	名称	出厂值	设定范围	说明
P8.29	量程小数点位数	1	0~3	0: 不显示小数点 1: 显示一位小数点 2: 显示两位小数点 3: 显示三位小数点 本参数只用于控制 P8.03、P8.25、P8.26、U.11 和 U.12 的小数点位数显示;
P8.30	缺水检测频率	48.00Hz	0.00Hz~ 最大频率	
P8.31	缺水检测压力	0.0	0.0~P8.28	
P8.32	缺水检测时间	60.0s	0~6500.0s	
P8.33	缺水重启时间	600.0s	0~6500.0s	
P8.34	缺水重启次数	6	9999	
P8.35	保留			
P8.36	光伏水泵运行模式	0	0~2	0: 不启用 1: 光伏水泵运行模式 1 2: 光伏水泵运行模式 2
P8.37	MPPT 低点工作电压	按机型	0~ MPPT 高点工作电压	若母线电压 (U-03) 高于 MPPT 高点工作电压 (P8.38) 设定值时, 以最大频率运行;若低于 MPPT 高点工作电压 (P8.38) 设定值时, 按 (母线电压/MPPT 高点工作电压)*最大频率所得频率运行, 如果母线电压达到 MPPT 低点工作电压 (P8.37)时, 以出水最低运行频率 (P8.44) 运行。
P8.38	MPPT 高点工作电压	按机型	MPPT 低点工作电压~1000V	
P8.39	缺水故障屏蔽	0	0~1	0: 不屏蔽 1: 屏蔽
P8.40	欠压重启使能	0	0~1	0: 不启用 1: 启用
P8.41	欠压重启延时	10.0s	0.0s~ 360.0s	延时时间从刚开始欠压的时候开始计时
P8.42	自启动	0	0~3	0: 不启用; 1: 上电自启动使能; 2: 故障复位后, 自启动使能; 说明: 如果开启以上两个功能, 设置为两个值的和, 即 3。
P8.43	光伏水泵缺水检测电流对应空载电流比例	0.0	0.0~ 300.0%	若变频器运行在最低出水频率 (P8.44) 以上, 且输出电流小于电机空载电流 (P9.11)*光优水泵缺水检测电流对应空载电流比例 (P8.43), 经过光伏水泵缺水检测时间 (P8.45) 后, 变频器报缺水故障 ELT。
P8.44	光伏水泵出水最低运行频率	0.00	0~ 99.99Hz	
P8.45	光伏水泵缺水检测时间	0.0	0~250.0s	
P8.46	摆频控值	0	0~1	0: 禁止 1: 有效
P8.47	摆幅控制	0	0~1	0: 固定摆幅; 摆幅参考值为最大输出频率 (P0.08)。 1: 变摆幅; 摆幅参考值为给定通道频率。
P8.48	摆频停机启动方式选择	1	0~1	0: 按停机前记忆的状态启动 1: 重新开始启动
P8.49	摆频幅值	0.0%	0.0%~ 100.0%	摆频幅值是相对于最大输出频率 (P0.08) 的百分比。
P8.50	突跳频率	0.0%	0.0%~ 50.0%	本功能码是指在摆频过程中, 当频率到达摆频上限频率之后快速下降的幅度, 当然也是指频率达到摆频下限频率后, 快速上升的幅度。该值是相对于摆频幅值 (P8.49) 的百分比, 设为 0.0%则无突跳频率。
P8.51	摆频上升时间	5.0s	0.1s~ 400.0s	从摆频下限频率到达摆频上限频率的运行时间。
P8.52	摆频下降时间	5.0s	0.1s~ 400.0s	从摆频上限频率到达摆频下限频率的运行时间。
P8.53	摆频下限频率延时	5.0s	0.1s~ 999.9s	设置摆频上下限频率延时。
P8.54	摆频下限频率延时	5.0s	0.1s~ 999.9s	
P8.55	保留			
P9 组-电机参数设置				
P9.00	额定功率	按机型		电机参数设置
P9.01	额定电压	按机型	1~500V	电机参数设置
P9.02	额定电流	按机型	0.01~99.99A	
P9.03	额定转速	按机型	0~6000rpm	
P9.04	额定频率	50.0Hz	1.0~400.00Hz	运行频率不能超过额定频率的 8 倍。例如运行 400Hz, 额定频率 P9.04 需 > 50.00Hz
P9.05	参数辨识	0	0~1	0: 不启用参数辨识; 1: 启用参数静态辨识, 辨识结束自动置 0;
P9.06	定子电阻	按机型	0.001~ 65.535Ω	不同机型, 有对应默认值, 参数辨识会自动改变数值;
P9.07 ~ P9.09	转子电阻、漏感、互感等	按机型		不同机型, 有对应默认值, 参数辨识会自动改变数值;
P9.11	空载电流	按机型	0.01~	设置电机空载电流; 不同机型, 有对应默认值, 参数辨识会自动改变数值;
P9.12	电机转速单位	1	1~2	1: 1rpm 2: 10rpm
PA 组-保护参数设置				
PA.00	过载保护	00	0000~9999	个位: 电机过载使能 十位: 变频器过载预警使能 (1: 端子功能输出), 变频器过载预警使能;2: 端子功能输出, 报故障停机
PA.01	电机过载保护系数	100%	30%~110%	电机过载保护系数为电机额定电流值对变频器额定输出电流值的百分比。
PA.02	欠压保护水平	180/360V	150~280V 250~480V	本功能码规定了当变频器正常工作的时候, 直流母线允许的下限电压。
PA.03	过压失速使能	1	0~1	0: 禁止 1: 使能
PA.04	过压限制水平	375/720V	350~380 660~790V	过压限制水平定义了过压失速保护时的动作电压
PA.05	电流限幅水平	150%	30%~200%	电流限幅水平定义了自动限流动作的电流阈值, 其设定值是相对于变频器额定电流的百分比。

参数	名称	出厂值	设定范围	说明
PA.06	限流时频率下降率	0	0~99.99Hz/s	
PA.07	限流动作选择	0	0~2	0: 无效 1: 加减速有效, 恒速无效 2: 加减速有效, 恒速有效
PA.08	变频器过载预警水平	120%	30~150%	变频器过载预警动作的电流阈值, 其设定值是相对于变频器额定电流的百分比。
PA.09	变频器过载预警延时	5.0s	0.0~60.0s	变频器输出电流从持续大于过载预警 (PA.08), 到输出过载预警信号间的延迟时间。
PA.10	振荡抑制系数	30	0~100	一般情况下, 出现电机振荡时, 增加振荡抑制系数。
PA.11	振幅抑制系数	20	0~1000	设定振荡抑制的最大调节量。
PA.12	振荡抑制下限频率	5.00Hz	0.0~振荡抑制上限频率 (200.00Hz)	低于此频率时, 振荡抑制无效。
PA.13	振荡抑制上限频率	50.00Hz	振荡抑制下限频率 (0.00~200.00Hz)	高于此频率时, 振荡抑制无效。
PA.16	故障自动复位次数	0	0~30	复位次数设置为 0 时, 无自动复位功能, 只能手动复位。
PA.17	故障自动复位间隔时间	3.0s	0.5~25.0s	设置故障自动复位间隔时间
PA.18	VF 过流、过压抑制使能	3	0~3	0: 无操作 1: 过流抑制使能 2: 过压抑制使能 3: 过流过压抑制使能
PA.19	VF 过流抑制 Kp	20	0~100	
PA.20	VF 倍速过流失速动作电流补偿系数	50	50~200	
PA.21	VF 过压抑制 Kp	60	0~100	
PA.22	VF 过压失速上升最大频率	5	0~50	
PA.23	VF 过压失速调压 Kp	80	0~100	
PA.24	掉电欠压停机方式	0	0~1	0: 报欠压故障, 自由停车; 1: 不报欠压故障, 按设定的停车方式 (P3.05) 停车。
PA.25	风扇控制 (适配部分机型)	1	0~1	0: 无效, 上电风扇转动, 断电风扇停止; 1: 有效: 按运行风扇转动, 按停止 12s 后风扇停止
PA.26	输出缺相使能	1	0~1	0: 输出缺相保护无效 1: 输出缺相保护使能
PA.27	直流制动电压	220V:370 380V:670	按机型 350~790	
PA.40	限流降频	0	0~6553	1: 限流降频使能; 2: 低压降频使能; 4: 保留; 8: 输入缺相使能; 说明: 如果开启多个功能, 设置为对应功能值之和即可。
PA.41	限流降频设定值	100.0%	0~180.0%	此参数以电机电流为计算基值 (PA.41 * P9.02) = 限流降频点
PA.42	限流降频不调频的窗口电流大小	1.0%	0.0~100.0%	以电机电流百分比计算
PA.43	每步降频量	0.05	0.01~50.00	
PA.44	限流降频最大量	50.0%	0.0~100.0%	以电机额定频率百分比计算
PA.45	输入缺相检测阈值	40	0~1000	
PA.48	低电压降频程度	2048	0~4096	
Pb 组-显示及特殊参数设置				
Pb.00	运行监控参数	0	0~15	主监控界面的默认显示项目。对应数字为 U 组参数。
Pb.01	停机监控参数	1	0~15	主监控界面的默认显示项目。对应数字为 U 组参数。
Pb.02	电机转速显示系数	1.00	0.01~99.99	用于校正转速刻度显示误差, 对实际转速没有影响。
Pb.03	当前故障	0	0~9999	当前故障代码
Pb.04	前一次故障	0	0~9999	前一次故障代码
Pb.05	前二次故障	0	0~9999	前二次故障代码
Pb.06	故障电压	0	0~9999	故障时母线电压
Pb.07	故障电流	0	0~999.9	故障时输出电流
Pb.08	故障设置频率	0	0~300.0	故障时设置频率
Pb.09	故障运行频率	0	0~300.0	故障时运行频率
Pb.10	计数与定时模式	103	000~304	个位: 计数到达处理, 0: 单周计数, 停止输出, 1: 单周计数, 继续输出, 2: 循环计数, 停止输出, 3: 循环计数, 继续输出。 十位: 保留 百位: 定时到达处理, 0: 单周定时, 停止输出, 1: 单周定时, 继续输出, 2: 循环定时, 停止输出, 3: 循环定时, 继续输出。 千位: 保留
Pb.11	计数器复位值设定	1	0~9999	设置计数器复位值
Pb.12	计数器检测值设定	1	0~9999	设置计数器检测值

参数	名称	出厂值	设定范围	说明
Pb.13	定时时间设定	0	0~9999s	设置定时时间
Pb.20	软件升级日期(年)			
Pb.21	软件升级日期(月, 日)			
Pb.22	显示软件版本	00.05		
Pb.23	产品系列	320		
Pb.24	停机和运行辅助显示(仅对双显示有效)	4	0~15	主监控界面的默认显示项目。对应数字为U组参数。
PP组-厂家参数设置				
PP.00	厂家密码		1~9999	系统设置专用密码

U组-监控参数组			
参数	名称	范围	最小单位
U0.00	输出频率(Hz)	0.00~400.00Hz	0.01Hz
U0.01	设定频率(Hz)	0.00~400.00Hz	0.01Hz
U0.02	输出电压(V)	0~999V	1V
U0.03	母线电压(V)	0~999V	1V
U0.04	输出电流(A)	0.00~999.9A	0.01A
U0.05	电机转速(Krpm)	0~60000Krpm	1Krpm
U0.06	模拟输入 AVI(V)	0.00~10.00V	0.01V
U0.07	模拟输入 ACI(mA)	0.00~20.00mA	0.01mA
U0.08	模拟输出 AO(V)	0.00~10.00V	0.01V
U0.09	端子状态(Relay, X1-X5)	0~3FH	1H
U0.10	温度	0~9999	0.1°C
U0.11	PID 给定值	PID 量程下限~PID 量程上限	1
U0.12	PID 反馈值	PID 量程下限~PID 量程上限	1
U0.13	当前计数值	0~9999	1s
U0.14	当前定时值(s)	0~9999s	1s
U0.15	变频器运行累计时间(h)	0~9999h	1h
U0.16	变频器上电累计时间(h)	0~9999h	1h
U0.17	U相电流采样偏置值	0~4095	
U0.18	V相电流采样偏置值	0~4095	
U0.19	W相电流采样偏置值	0~4095	
U0.20	保留		
U0.21	保留		
U0.22	保留		

故障代码			
故障码	名称	故障可能原因	故障对策
OU1 (1)	加速运行中过压	输入电压异常	检查输入电源
		对旋转中的电机进行再启动	设置为直流制动后启动
OU2 (2)	减速运行中过压	减速时间太短	延长减速时间
		输入电压异常	检查输入电源
OU3 (3)	匀速运行中过压	输入电压异常	检查输入电源
OCC1 (4)	硬件加速过流	加速时间太短	延长加速时间
		变频器功率偏小	选用功率等级大的变频器
		V/F 曲线或转矩提升设置不当	调整 V/F 曲线或转矩提升量
		IGBT 模块损坏	联系供应商, 寻求服务
OCC2 (5)	硬件减速过流	减速时间太短	延长减速时间
		变频器功率偏小	选用功率等级大的变频器
		IGBT 模块损坏	联系供应商, 寻求服务
OCC3 (6)	硬件恒速过流	电网电压偏低	检查输入电源
		负载发生突变或异常	检查负载或减小负载突变
		变频器功率偏小	选用功率等级大的变频器
		IGBT 模块损坏	联系供应商, 寻求服务
OCS1 (7)	软件加速运行中过流	加速时间太短	延长加速时间
		变频器功率偏小	选用功率等级大的变频器
		V/F 曲线或转矩提升设置不当	调整 V/F 曲线或转矩提升量
OCS2 (8)	软件减速运行中过流	减速时间太短	延长减速时间
		变频器功率偏小	选用功率等级大的变频器
OCS3 (9)	软件匀速运行中过流	电网电压偏低	检查输入电源
		负载发生突变或异常	检查负载或减小负载突变
		变频器功率偏小	选用功率等级大的变频器

EFO (10)	功率模块故障	变频器输出短路或接地	检查电机接线
		变频器瞬间过流	参见过流对策
		控制板异常或干扰严重	向厂家寻求服务
		功率器件损坏	向厂家寻求服务
OU (11)	停机时 过压	输入电压异常	检查电源电压
OU3 (12)	恒速过压	电源电压过高	检查电源是否过高
		负载发生突变或异常	检查负载或减小负载突变
LU (13)	欠压	输入电压异常	检查电源电压
		继电器未吸合	向厂家寻求服务
OH (14)	过温	环境温度过高	改善环境
		变频器周围空间小	调整空间
		风道堵塞	清洁、疏通风道
		冷却风扇不运转	检查风扇的电源和风扇本身
OL2 (15)	变频器 过载	V/F 曲线或转矩提升设置不当	调整 V/F 曲线和转矩提升量
		电网电压过低	检查电网电压
		加速时间太短	延长加速时间
		电机负载过重	选择功率更大的变频器
OL1 (16)	电机过载	V/F 曲线或转矩提升设置不当	调整 V/F 曲线和转矩提升量
		电网电压过低	检查电网电压
		电机堵转或负载突变过大	检查负载
		电机过载保护系数设置不正确	正确设置电机过载保护系数
BIAS (17)	电流偏置 错误	硬件故障	联系供应商，寻求服务
CBC (18)	逐波限流 故障	变频器功率偏小	选用功率等级大的变频器
		负载发生突变或异常	检查负载或减小负载突变
FBL (19)	PID 反馈 低下限值	PID 反馈线路松动	检查反馈连线
		反馈量小于断线检测值	调整检测输入阈值
FBH (20)	PID 反馈 超上限	当 PID 反馈量大于反馈超值 检测值，且持续时间超过 PID 反馈超值检测时间后，变频器 报警故障 FBH	检查反馈连线 调整检测输入阈值
EEEP (21)	EEPROM 读写错误	EEPROM 故障	向厂家寻求服务
CE (22)	双 CPU 通讯故障	CPU 通讯故障	向厂家寻求服务
EF (23)	外部设备 故障	外部设备故障输入端子闭合	断开外部设备故障输入端子并清除故障（注意检查原因）
EPA (24)	参数设置 故障		
OLP (26)	参数辨识 输出缺相	参考故障代码 29	检查通讯线路连接是否异常，线序是否正确。
SFOC (27)	软件过流		调节加速，减速时间；电机参数不匹配，重新参数辨识；
ELH (28)	缺水故障		
SPO (29)	输出缺项 故障	变频器到电机接线不正常	排除接线故障
		变频器三相输出不平衡	检查电机三相绕组是否正常
		驱动板异常	向厂家寻求服务
		模块异常	向厂家寻求服务
OL3 (33)	变频器过 载预警故 障	变频器即将过载	
AUTH (34)	未授权	未走出厂授权流程。	返厂。
LCP (35)	输入缺相	输入缺相。	检查输入电路。
警告代码			
EPA1	参数设置 错误	变频器三线制功能设置不正确	检查变频器端子三线制设置是否正确
SLEP	休眠模式	变频器进入休眠模式	